

H. HERMANN EHLERS GMBH

Fördern - Messen - Regeln - Dosieren - Verdichten
Ingenieurbüro - Werksvertretungen

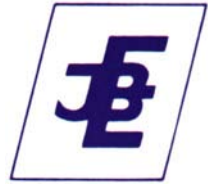

USE AND SERVICE MANUAL

OIL METER

P.D. METERS TYPE

LBM 1000 AND LBM 3000

CONTENTS

<u>SECTION</u>	<u>TITLE</u>	<u>Page</u>
1	Introduction	1
2	Operation	1
3	General rules for meters installation	2
4	Meters protection during storage periods	2
5	Meters dismounting and overhaul	3
6	Disassembly	3
7	Main components test and overhaul	5
8	Meters reassembly	6
9	Slacks' table	7
10	Calibration mechanism	7
11	Calibration	8
12	Tests after overhaul	9
13	Suggested lubricating oils for calibrating mechanism	9
14	Mechanical counters	9
15	Special tools	10

ENCLOSED:

- Overall dimensions – P.d.meter type LBM 1000 Dwg. n. 2820-2821
- Overall dimensions – P.d.meter type LBM 3000 Dwg. n. 2818-2819
- Exploded view of LBM 1000 Dwg. n. 3288
- Exploded view of LBM 3000 Dwg. n. 3287
- Exploded view of mechanical seal Dwg. n. 3291/2
- Exploded view of magnetic drive Dwg. n. 3291
- Exploded view of calibrating mechanism and spacer Dwg. n. 3289
- Exploded view of temperature compensator and spacer Dwg. n. 3290
- Exploded view of spacer and calibration mechanism Dwg. n. 672/LBM
- Gearing box for mounting with VEGA counter Dwg. n. 3958



WARNING

All the parts under pressure must be released before disassembling the p.d.meter or its accessories for inspection or components replacement.

Whenever the p.d.meter is connected to a pipe section intercepted by two valves, such section must be protected by an appropriate overpressure valve against thermal expansions of the liquid. This to avoid that the pressure in line exceeds the value of the maximum working pressure stated on the data label of the p.d.meter.

1 INTRODUCTION

"OIL METER" positive displacement meters are precision measuring instruments designed for use with a variety of petrochemical products and liquids. Each meter is fully tested and calibrated by factory before despatch, and a regular service will maintain a high standard of performance and accuracy.

Special tools have been designed to facilitate overhaul operations and we strongly recommend their use (see page 10). If the accuracy of the meter varies beyond accepted limits or if mechanical defects appear, meter should be overhauled and recalibrated.

Experience has shown that mechanical defects are usually caused by the entry of foreign matters into the metering compartment due to inadequate straining facilities in the pipeline.

It is most important therefore that an efficient strainer is installed in the system and inspected at regular intervals to insure a correct functioning.

2 OPERATION (see FIG. No.1)

Liquid enters the meter through the existing space between the measuring chamber and the external housing. Then it enters the measuring chamber through the specific passages and, by pressure on the vanes causes the rotor to revolve (figure no.1).

The measured amount is sealed between two adjacent vanes of the measuring chamber and then passes through the outlet port. Fitted with mechanical or magnetic seal. The LBM serie is available with one measuring chamber for the LBM 1000 and two for the LBM 3000 thus giving maximum flow rate.

FIG.No.1

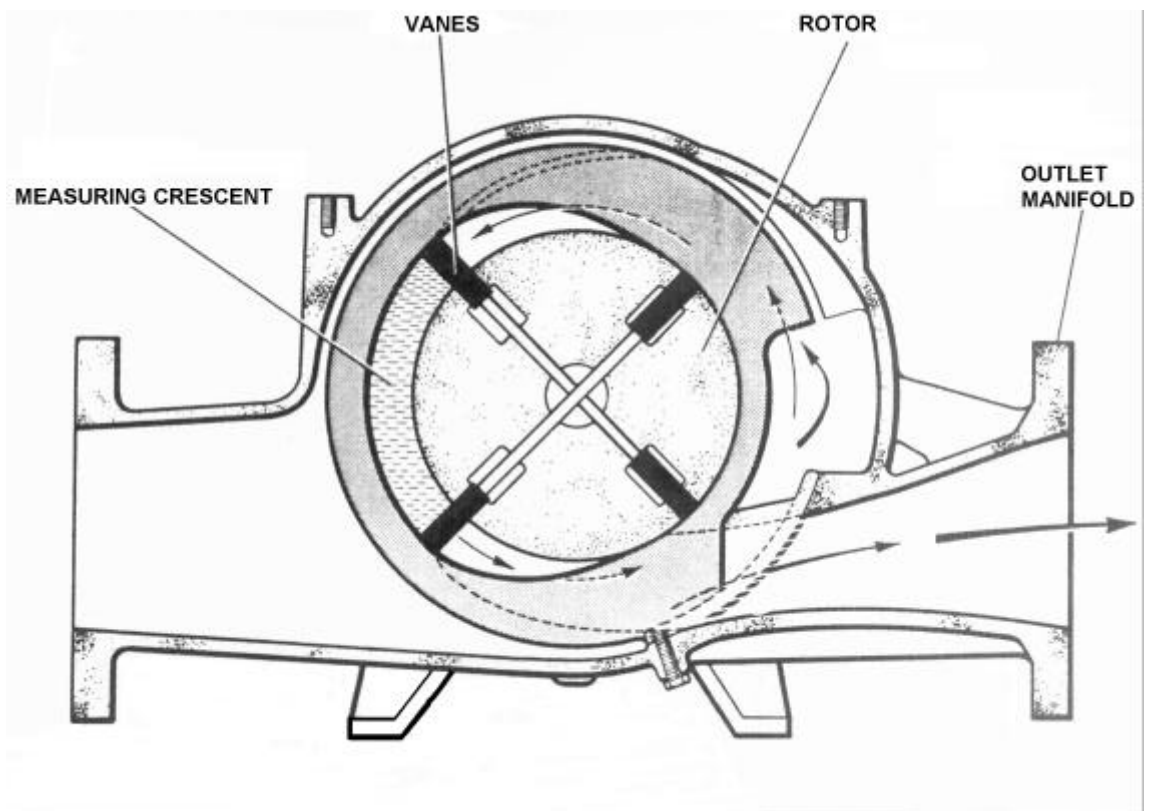

3 GENERAL RULES FOR METERS INSTALLATION

- P.D. Meters must be horizontally installed as indicated in figure 1.
- Meters must be installed in such a way that air or vapour do not enter through the liquid under measurement. Should this happen the best would be to install an air separator upstream the meter.
IMPORTANT: pipe discharging gaseous parts should remain always open.
- To protect meter from damages due to entrained foreign matters in the liquid, a suitable strainer must be installed upstream the meter. Stainless steel basket with 60 mesh for gasoil (or diesel-oil) and 100 mesh for gasoline (or kerosene) is required.
- In case the rate of flow through the installation should exceed the meter maximum rated capacity, it is advisable to use a flow limiting valve.
- To avoid hammer shocks which may strongly damages the meter, it is not advisable to install upstream or downstream the meter any quick closing valves.
- In new installations it is necessary, before mounting the meter, to wash the pipeline flowing product thus eliminating eventual dirty particles which may cause blocking of the meter.
- During starting operations, is advisable gradually to open the valves in order to slowly eliminate the air. Not making this operation means to set a high speed to rotor due to the air compression in the pipe; it may damage internal components as well.

4 METERS PROTECTION DURING STORAGE PERIODS

- 4.1 If the meter or the equipment of the system are not immediately used, or if it is withdrawn from service and stored, it is important to follow next instructions :
- a) fill the meter and its accessories with clean kerosene or lubricated oil and close its ends with blank flanges;
 - b) fill the carter containing the calibrating mechanism with oil till the sight glass is reached ;
 - c) adequately protect counters against rain and dust, with damp-proof caps;
 - d) if after a working period it is foreseen to stop the meters for a long time, before to follow the above points, drain the meter and its accessories;

5 METERS DISMOUNTING AND OVERHAUL

To overhaul the meter from the plant proceed as follows:

- a) Ensure that valves upstream the meter are closed.
- b) Drain the pipelines by means of the drain plug placed on the meter base. Take care that a small quantity of liquid remains inside.
- c) Drain oil from calibrating mechanism by removing the drain plug placed on the base of the housing containing the same mechanism (see Dwg.672)
- d) Remove bolts from manifold flanges.
- e) Withdraw meter from the installation by using suitable lifting equipments.

N.B.: If the overhaul is simple, it is not necessary to remove the meter from the pipe.

6 P.D. METER DISASSEMBLY (dwg. 3287-3288)

To facilitate disassembling operations take into consideration that each p.d.meter is made up of two main groups:

- a) body
- b) calibration mechanism and counter.

The temperature compensator (if present) is described in its own service and maintenance manual.

5.1 Main components disassembling

- a) Break and remove seals placed on the bottom of the counter, unscrew the 4 screws (item 56 dwg.672) and remove the counter.
- b) Unscrew bolts (item 12 dwg.3289) fixing spacer to the cover and remove the complete mechanism group (see item 18-50 dwg.3289).

5.2 Mechanical seal or magnetic drive and external front cover disassembling

- a) Remove screws (item 28 dwg.3291 and 3291/2) and withdraw complete drive set from cover calibrated hole.
- b) Remove screws (item 1 dwg.3287) fixing the external front cover and release cover taking care of the OR gasket (item 93).

5.3 Internal measuring chamber removal (dwg.3287 – 3288)

To remove the internal measuring chamber the best way is to remove it towards the top after having put the p.d.meter so as to get the spin axis in vertical position.

For LBM 3000 this involves to remove also the rear cover.

To support the chamber during the operation we suggest to use two eyebolts M8 threaded screwing them instead of two screws (item 79) fixing the cover to the internal chamber.

After this operation release the measuring chamber removing the screws (item 86) of which five are screwable from the external of the body while the other two from inside (they are accessible through the outlet of the body)

In case of the LBM 3000, which is fitted of two measuring chambers, proceed to disassemble the connection joint.

5.4 Measuring chamber disassembling (dwg.3287 – 3288)

During disassembling the measuring chamber of LBM 3000 keep the components of each chamber separated, because they are not interchangeable among themselves. Extract the spiral pin (item 27) from the rotor shaft (item 83) and remove the plate (item 94) with the springs holder bushes (item 95) unscrewing the 8 screws (item 73). Keep the springs (item 96) and the thrusting bearing disc (item 97). Unscrew the screws (item 79) to separate the same cover to the measuring chamber. Use the tool page 10 item A), blocking it on the rotor shaft by two screws. By this the complete rotor may be removed from the measuring chamber.

5.5 Rotor-vanes group disassembling (dwg.3287 – 3288)

NOTE: For the LBM 3000 before proceeding in disassembling the rotor assembly, take note of the position of the vanes which will have to correspond to its own housings into the rotor, marking each vane and each housing; this will make easier the re-assembling operation.

The reusable vanes will have to be reassembled in their original housings.

For disassembling proceed as follows:

- a) For each vanes assembly act on the vane to the opposite adjusting nuts (in the drawings this vane is represented in the inferior position).
- b) Remove the split pin (item 129) from each tie rod.
- c) Remove paying attention the remaining vane fitted with two washers (item 136) taking into consideration that these last ones will have to be reassembled in their original position.
- d) Remove from the rotor the remaining vane fitted with tie rods. Do not withdraw the vane from its own tie rods unless it is damaged or worn and for this reason its replacement is necessary.

CAUTION: never loosen the adjusting nuts (item 133) of the clearances between vanes and measuring chamber.

- e) To avoid some exchanges insert temporarily each couple of vanes again, after having removed them from the rotor, on their own tie rods.
- f) The bushes inserted into the rotor must be removed in the following way:
 - Remove the blocking plate (item 10) unscrewing the screw (item 77);
 - Turn over the rotor and make the bush (item 107), the washers (item 108) and the bush (item 109) come out.

CAUTION: as these components will be reassembled in their original position, every change among themselves must be avoid.

5.6 Mechanical seal disassembling (dwg.3291/2)

- a) Remove the whole group unscrewing the screws (item 28)
- b) Withdraw the pin (item 55) from the shaft (item 42)
- c) Remove the elastic ring (item 24)
- d) Unscrew the 4 screws (item 25)
- e) Remove the bush (item 36) with the bearing (item 14) and the OR (item 37)

Note: During the reassembling pay attention to the right positioning of the fixing pin for the graphite bush of the seal.

Check the condition of the OR and replace them if worm or swelled.

- f) The reassembling operation is performed by repeating the previous instructions on the contrary sense.

5.7 Magnetic drive disassembling (dwg.3291)

- a) Remove from the spacer the external magnet (item 157) withdraw the pin (item 55) and withdraw the shaft (item 158 or 158/A in case of presence of temperature compensator).
- b) Withdraw the shaft-magnet group from the flange.
- c) Remove the coupling from the opposite extremity of the shaft (item 162).
- d) Loosen the nut (item 145) and withdraw the washer (item 148) with inside the bearing (item 149), the spacer (item 147) and the internal magnet (item 154).

Check the condition of the OR and replace them if worm or swelled.

- e) The reassembling operation is performed by repeating the previous instructions on the contrary sense.

7 CHECK AND OVERHAUL OF THE MAIN COMPONENTS

7.1 Measuring chamber check

- a) Be sure that the chamber do not have grooves or wears.
- b) Clean all components with care.
- c) Replace always all the OR gasket.

7.2 Rotor-vanes group check

- a) Check that the couple of vanes are not damaged or worn. If there are clear signs of wear the couple of vanes are to be replaced.
- b) Check that the bushes of the rotor may move freely inside their housings and that they are not worn.
- c) Clean all components with care.

7.3 Adjusting of clearances among rotor and covers

The following instructions regards the p.d. meter type LBM 1000 (dwg.3288); for LBM 3000 (dwg.3287) see notes signed with (**) symbol.

- a) Insert the rotor (without vanes) in the measuring chamber, laying it to the spacer (item 140) with the screw (item 143) completely loosen.

(**) For LBM 3000 the 8 screws (item 73) are to be loosened so as the rotor lays on the rear cover of the measuring chamber.

- b) Assemble the front cover (item 99) and the plate with the springs (item 94 and 97).
- c) By using an iron base fixed on the front cover with one of the screws (item 79), measure by a comparator with magnet base, the total rotor-cover clearance, screwing completely the screw (item 143).

(**) For LBM 3000 the total clearance is measured by screwing completely 4 of the 8 screws (item 73) after having stated, by a thickness gauge, the external clearance of the cover (item 115).

- d) Check that the total rotor-cover clearance is between $0,15 \pm 0,25$ mm (see § 9).
- e) Unscrewing the screw (item 143) again, divide in half the total clearance measured as above and block the adjusting screw with the self-locking nut (item 142).

EXAMPLE: total clearance = 0,18 mm

Divide it so as to get 0,09 mm between the rotor and the front cover and 0,09 mm between rotor and rear cover.

Lock the remaining screws (item 73).

- f) Remove the front cover (item 99) and the base plate of the temperature compensator (in case there is); withdraw the rotor and proceed in assembling the vanes without moving the adjusting screw (or the cover item 115 for LBM 3000) any more.

NOTE: If during disassembling into the front cover a Mylar sheem has been found (which not always is assembled between measuring chamber and cover), such sheem is to be placed in its original position as on the contrary it would vary the value or the total clearance stated.

7.4 Adjusting of the vanes length

- a) Use the tool (see pag.10 fig. E) previously zeroized by its suitable measuring template.
- b) The length of the vanes group is adjusted by using the two nuts (item 133) and arrange that it corresponds exactly to the length of the template.
- c) Put the couple of vanes in the measuring sector of the measuring chamber (see fig.1). Check by a thickness gauge that the total clearance among the chamber and the vanes is between $0,20 \pm 0,25$ mm.
On the contrary repeat the adjusting operation of the length to get the clearance wished.

8 P.D.METER REASSEMBLING

During this operation clean each components before to reassemble it with care, so as any foreign matter may enter into the p.d.meter.

Some reassembling operations are not described here below as they are to be performed, repeating exactly, but in the contrary sense, the disassembling operation.

During reassembling it is advisable to replace the OR gasket.

8.1 Reassembling the vanes into the rotor

- a) Making this operation, for each couple of vanes, act on the vane opposite to the adjusting nuts without moving such nuts no more as it should vary the length of the vanes group.
- b) Remove the split pins (item 129) and withdraw the vane from the tie rods paying attention to collect the washers, the springs and the bushes which will have to be reassembled in the same position.
- c) Remove the washers (item 123) and pay attention that they are reassembled into the same position and support sense.
- d) Insert into the rotor the vane fitted with the tie rods, joining the vane hole to the rotor hole.

- e) Check by a thickness gauge that the clearance between rotor hole and vane is included between 0,20 ÷ 0,25 mm.
- f) Reassemble on the opposite side the vane previously kept away repeating on the contrary the operation previously stated.

8.2 Reassembling of the rotor fitted with vanes (dwg.3288)

- a) Insert the rotor in the measuring chamber laying its external surface in the sector of the measuring chamber having the minimum bending radius.
- b) Reassemble the front cover finishing in such way the assembling of the internal chamber.

8.3 Assembling finishing

The reassembling of the meter is completed when the measuring chamber is inserted again into the external body.

(**) For LBM 3000 the operation included also the timing of the flange of the connection joint among the two chambers. This operation causes the alignment of the two reference signes stated on the rotor shaft and on the semi-joint (see also notes on dwg.3287)

On inserting the second chamber take care to engage rightly the semi-joints among themselves.

9 TABLE OF THE CLEARANCES TO BE CHECKED DURING REASSEMBLING

TYPE OF CLEARANCE	VALUE IN MM
Rotor - covers (to divide half on the front and half on the rear)	0,15 ÷ 0,25
Vanes - chamber	0,20 ÷ 0,25
Vanes - rotor hole	0,20 ÷ 0,25

10 CALIBRATING MECHANISM

The calibrating mechanism comprises a train of gears which transmit movement of the rotor to the counter. Operational failures of the mechanism are rare and they generally regard the breaking of tension pin, due to an excessive strain.

It is recommended to repair without varying the calibrating adjustment.

Attention: do not take off the shimming washers between the frame and the bearing of the mechanism box.

11 CALIBRATION OF P.D.METER LBM SERIES (see FIG. No.2)

To carry out meter calibration follow next procedures:

- a) Break and remove seals.
- b) Remove the three screws (1) securing the cover (2) to the housing (3) in which calibrating mechanism is fitted.
- c) Remove cover (2)
- d) By using square key (4 mm) turn shaft (4) till A, B, C holes placed on the bracket (5) and on friction roller (6) will be properly aligned.
- e) Insert in these holes the stop pin (supplied with the meter, then using the square key operate on the shaft (4) as follow :
 - turning anticlockwise direction, even if the quantity of fluid does not vary, on the counter is obtained an higher volume indication;
 - turning clockwise direction it is obtained a lesser indication.

Note: one complete turn of the screw varies the volume indicated on the meter by approximately 0,18 per cent.

FIG. No.2

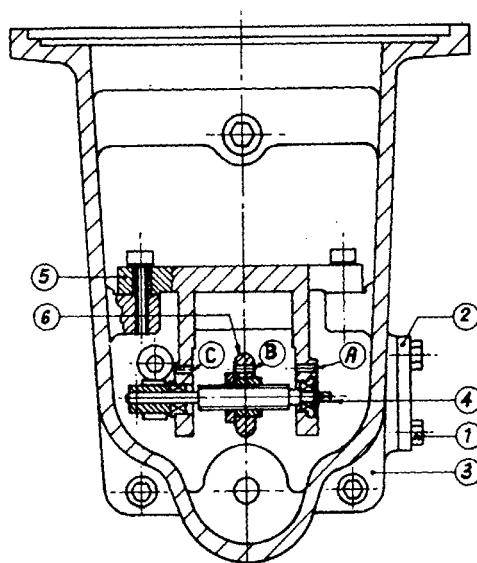

12 TESTS AFTER OVERHAUL

After overhaul, meter must be tested by a suitable proving system.

As per Italian Weight and Measure Office rules the value stated by the counter of the p.d.meter compared with the volume stated by the level of the measuring chamber, must be contained between +0,3% and -0,2%.

EXAMPLE	COUNTER READING	PROVING TANK READING
	1000	1003 (+ 0,3%)
	1000	998 (- 0,2%)

13 SUGGESTED LUBRICATING OILS FOR CALIBRATING MECHANISM

<i>COMPANY</i>	<i>TYPE OF OIL</i>	<i>TEMPERATURE RANGE</i>
AGIP	OTE 32 SINT 2000	-10 ÷ + 60°C -40 ÷ +225°C
ESSO	NUTO 32	-20 ÷ + 65°C
IP	HINDRUS HI 46	-10 ÷ + 60°C
SHELL	AEREOSHELL FLUID 31	-40 ÷ +204°C
MOBIL	DTE 26 MOBIL 1	-10 ÷ + 80°C -10 ÷ +200°C

NOTE : to avoid ice forming in winter time, add two spoons of car antifreeze.

14 MECHANICAL COUNTERS

See special manuals.

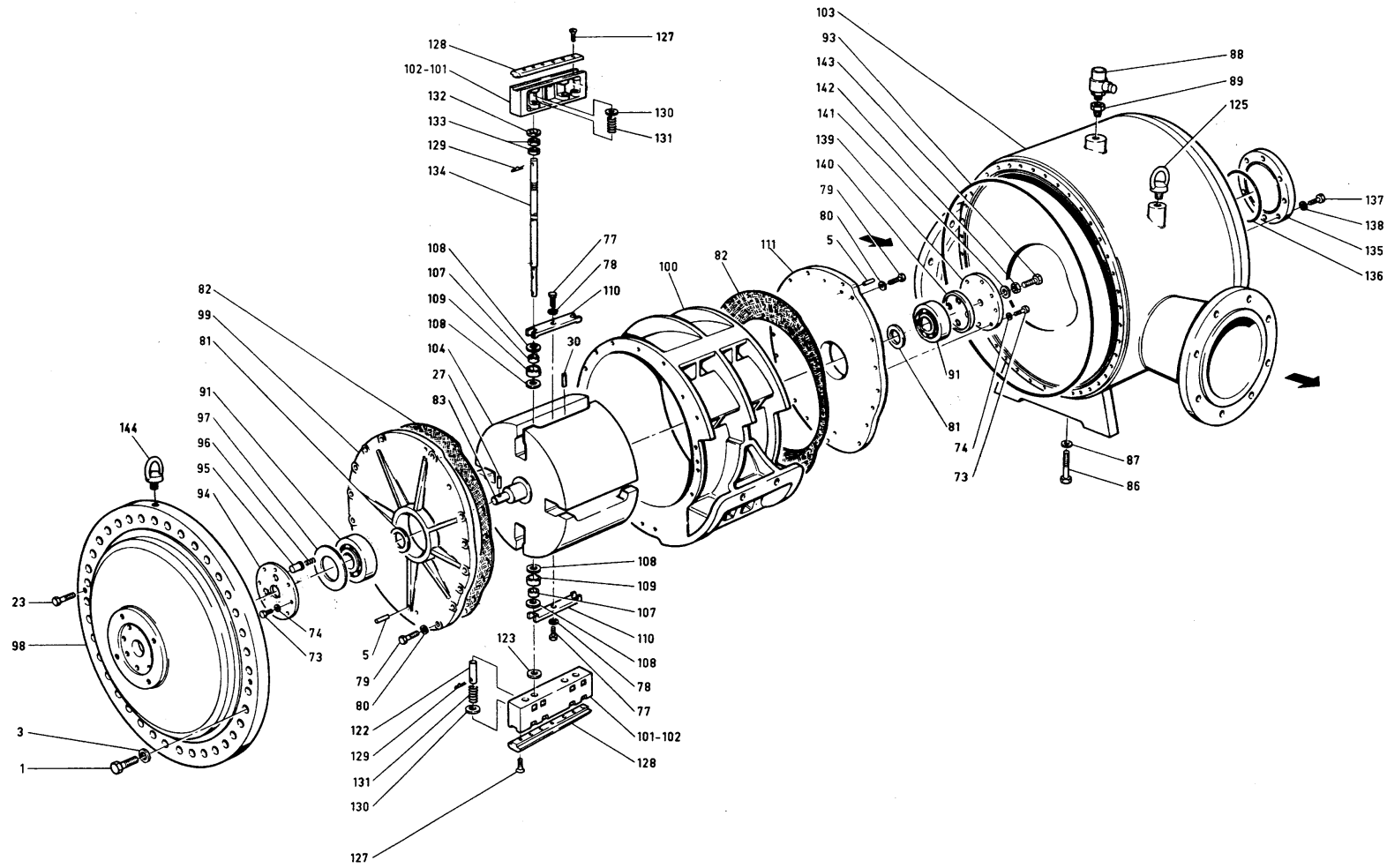

					P.D.METER LBM 1000					Dis. 3288	
										Page 1 of 2	
<i>item</i>	N° CODE	<i>DESCRIPTION</i>	Q.ty	MATERIAL	<i>item</i>	N° CODE	<i>DESCRIPTION</i>	Q.ty	MATERIAL		
1	80VI2246	Screw	38	Carbon steel	95	80BU1063	Spring bush	3	St. steel		
3	80RO1189	Elastic washer	38	Carbon steel	96	80MO0078	Spring	3	St. steel		
5	80SP6026	Cylindrical pin	4	Carbon steel	97	80DI3165	Load distributor disc	1	St. steel		
23	80VI2171	Screw	2	Carbon steel	98	80COB081	Front cover	1	Carbon steel		
27	80SP5084	Spirol pin	1	Carbon steel	99	80COB105	Rotor front cover	1	Cast iron		
30		Supplied with item 104			100	80CA1006	Measuring chamber	1	Cast iron		
73	80VI2066	Screw	16	Carbon steel	101*	80PA1060	Right vane	2	Aluminium		
74	80RO1204	Spring washer	16	Carbon steel	102*	80PA1060	Left vane	2	Aluminium		
77	80VI2075	Screw	4	Carbon steel	103	80CA8078	Lh ext.housing fl.ANSI 150	1	Carbon steel		
78	80RO1351	Safety washer	4	Carbon steel	103	80CA8079	Lh ext.housing fl.ANSI 150	1	Carbon steel		
79	80VI2132	Screw	36	Carbon steel	104	80RO2027	Rotor assembly	1	Cast iron		
80	80RO1207	Spring washer	36	Carbon steel	107*	80RO1084	Bush	8	Teflon		
81	80RO1165	Washer	2	St. steel	108*	80RO1114	Washer	16	Brass		
82		Sheem	2		109*	80BU1066	Bush	8	AISI 304		
82		Sheem	2		110	80PI2006	Locking plate	4	Brass		
83		Supplied with item 104			111	80COB387	Rotor rear cover	1	Cast iron		
86	80VI2210	Screw	7	Carbon steel	122*		Supplied with item 134				
87	80RO1249	Washer	7	Copper	123		Supplied with item 134				
88	80VA6006	Safety valve	1	Carbon steel	125	80GO0018	Eyebolt	2	Carbon steel		
89	80RI1075	Reduction	1	Carbon steel	127	80VI7031	Screw	24	St. steel		
91*	80CU1018	Bearing	2	St. steel	128*		Supplied with item 101				
93*	80GU1168	"O" ring seal	1	Nirile	129	80COD006	Split pin	8	St. steel		
94	80PI1033	Plate	1	Carbon steel	*Suggested spare parts						

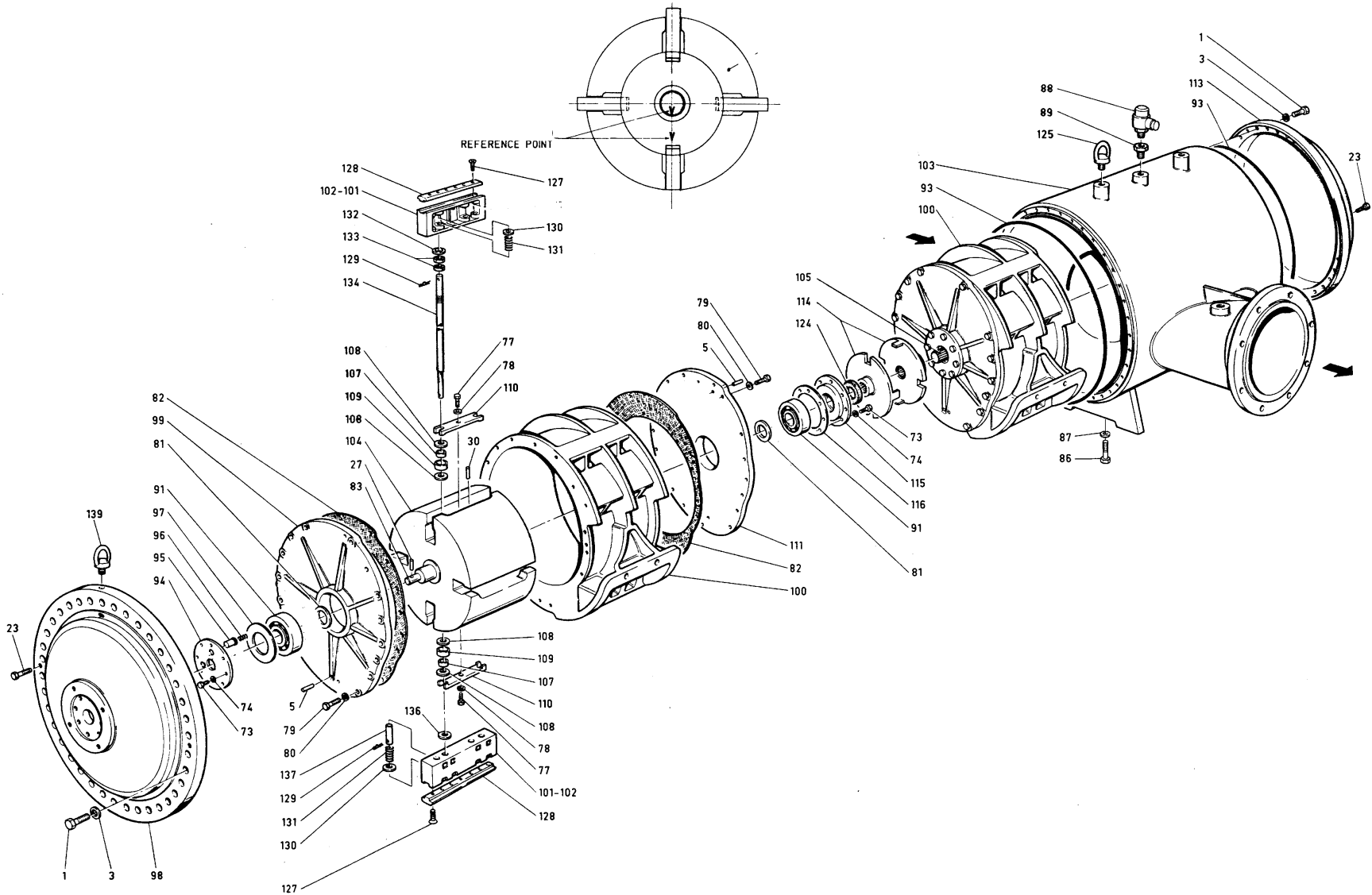

					Dis. 3287				
					P.D.METER LBM 3000				
					Page 1 of 2				
<i>item</i>	<i>N° CODE</i>	<i>DESCRIPTION</i>	<i>Q.ty</i>	<i>MATERIAL</i>	<i>item</i>	<i>N° CODE</i>	<i>DESCRIPTION</i>	<i>Q.ty</i>	<i>MATERIAL</i>
1	80VI2246	Screw	76	Carbon steel	95	80BU1063	Spring bush	6	AISI 304
3	80RO1189	Elastic washer	76	Carbon steel	96	80MO0078	Spring	6	St. steel
5	80SP6026	Cylindrical pin	8	Carbon steel	97	80DI3165	Load distributor disc	2	AISI 304
23	80VI2171	Screw	4	Carbon steel	98	80COB081	Front cover	1	Carbon steel
27	80SP5084	Spirol pin	1	Carbon steel	99	80COB105	Rotor front cover	2	Cast iron
30		Supplied with item 104			100	80CA1006	Measuring chamber	2	Cast iron
73	80VI2066	Screw	32	Carbon steel	101*	80PA1060	Right vane	4	Aluminium
74	80RO1204	Spring washer	32	Carbon steel	102*	80PA1060	Left vane	4	Aluminium
77	80VI2072	Screw	8	Carbon steel	103	80CA8087	External housing	1	Carbon steel
78	80RO1351	Safety washer	8	Carbon steel	104	80RO2015	Ant. rotor assembly	1	Cast iron
79	80VI2132	Screw	72	Carbon steel	105	80RO2018	Rear rotor assembly	1	Cast iron
80	80RO1207	Spring washer	72	Carbon steel	107*	80BO1084	Bush	16	Teflon
81	80RO1165	Washer	4	St. steel	108*	80RO1114	Washer	32	Brass
82		Sheem	2		109*	80BU1066	Bush	16	AISI 304
82		Sheem	2		110	80PI2006	Locking plate	8	Brass
83		Supplied with item 104			111	80COB387	Rotor rear cover	2	Cast iron
86	80VI2210	Screw	14	Carbon steel	113	80COV336	Rear cover	1	Carbon steel
87	80RO1249	Washer	14	Copper	114	80FL0216	Coupling flange	2	Carbon steel
88	80VA6006	Safety valve	1	Carbon steel	115	80AN1000	Locking ring	1	Carbon steel
89	80RI1075	Reduction	1	Carbon steel	116		Sheem	2	
91*	80CU1018	Bearing	4	St. steel	125	80GO0018	Eyebolt	2	Carbon steel
93*	80GU1168	"O" ring seal	1	Nirile	127	80VI7031	Screw	48	St. steel
94	80PI1033	Plate	1	Carbon steel	*Suggested spare parts				

					Dis. 3291				
					MAGNETIC COUPLING FOR LBM 1000 - 3000 METERS				
					Page 1 of 1				
item	N° CODE	DESCRIPTION	Q.ty	MATERIAL	item	N° CODE	DESCRIPTION	Q.ty	MATERIAL
28	80VI4267	Screw	8	Carbon steel					
29	80RO1180	Spring washer	8	Carbon steel					
33*	80GU1459	O ring seal	1	Viton					
55	80SP5012	Spirol pin	4	Carbon steel					
145	80DA3048	Nut	1	Carbon steel					
146	80FL0186	Gap flange	1	St. steel					
147	80RO1147	Washer	1	St. steel					
148	80RO1141	Lock washer	1	St. steel					
149	80CU1027	Bearing	1	St. steel					
150	80SP5063	Spirol pin	1	Carbon steel					
154*	80MA0033	Protected magnet	1	Oxit 100					
156	80AL0024	Shaft	1	Carbon steel					
157*	80MA0027	External magnet	1	Oxit 100					
158	80AL0024	Shaft	1	St. steel					
158 A	80AL0015	Shaft	1	St. steel					
159	80AN2036	Elastic ring	1	Carbon steel					
160		Supplied with item 157							
161	80CU1066	Bearing	3	St. steel					
162	80AL0150	Shaft and coupling	1	St. steel					
163	80SP5069	Spirol pin	1	Carbon steel					
					* Suggested spare parts				

T-3291.XLS

		SPACER AND CALIBRATION MECHANISM FOR APPLICATION WITHOUT TEMP. COMPENSATOR ON THE LBM 1000-3000 METERS						Dis.3289	
<i>item</i>	<i>N° CODE</i>	<i>DESCRIPTION</i>	<i>Q.ty</i>	<i>MATERIAL</i>	<i>item</i>	<i>N° CODE</i>	<i>DESCRIPTION</i>	<i>Q.ty</i>	<i>MATERIAL</i>
2	80CU1066	<i>Bearing</i>	1	<i>St. steel</i>	70	81PI1003	<i>Gear pl.LBM 3000 LH</i>	1	
4	80AN2036	<i>Elastic ring</i>	2	<i>St. steel</i>					
6	80VI4201	<i>Screw</i>	2	<i>Carbon steel</i>					
7	80DA1018	<i>Nut</i>	1	<i>Carbon steel</i>					
8	80VI4279	<i>Screw</i>	1	<i>Carbon steel</i>					
9	80RO1261	<i>Plate washer</i>	1	<i>Carbon steel</i>					
10	80RO1180	<i>Spring washer</i>	4	<i>Carbon steel</i>					
11	80PR3066	<i>Stud</i>	4	<i>Carbon steel</i>					
12	80DA1018	<i>Nut</i>	4	<i>Carbon steel</i>					
13*	80GU1243	<i>Gasket</i>	1	<i>Viton</i>					
18	80SC2000	<i>Calibrat.mech.box</i>	1	<i>Aluminium</i>					
19	80DI5006	<i>Calibrating mechanism</i>	1						
21	80VI4006	<i>Screw</i>	3	<i>St. steel</i>					
22	80FL0093	<i>Flange</i>	1	<i>St. steel</i>					
43	80MA1009	<i>Sleeve</i>	1	<i>Carbon steel</i>					
49	81TE0003	<i>Net volume counter</i>	1						
50	80COB402	<i>Magnetic coupl.cover</i>	1	<i>Aluminium</i>					
52	80AL0072	<i>Shaft</i>	1	<i>St. steel</i>					
55	80SP5012	<i>Spirol pin</i>	3	<i>Carbon steel</i>					
67*	82GU0033	<i>Lip seal ring</i>	1	<i>Viton</i>					
70	81PI1009	<i>Gear plate LBM 1000</i>	1						
70	81PI1006	<i>Gear pl. LBM 3000 RH</i>	1						
70	81PI1003	<i>Gear pl.LBM 3000 LH</i>	1		*Suggested spare parts				

T-3289.XLS

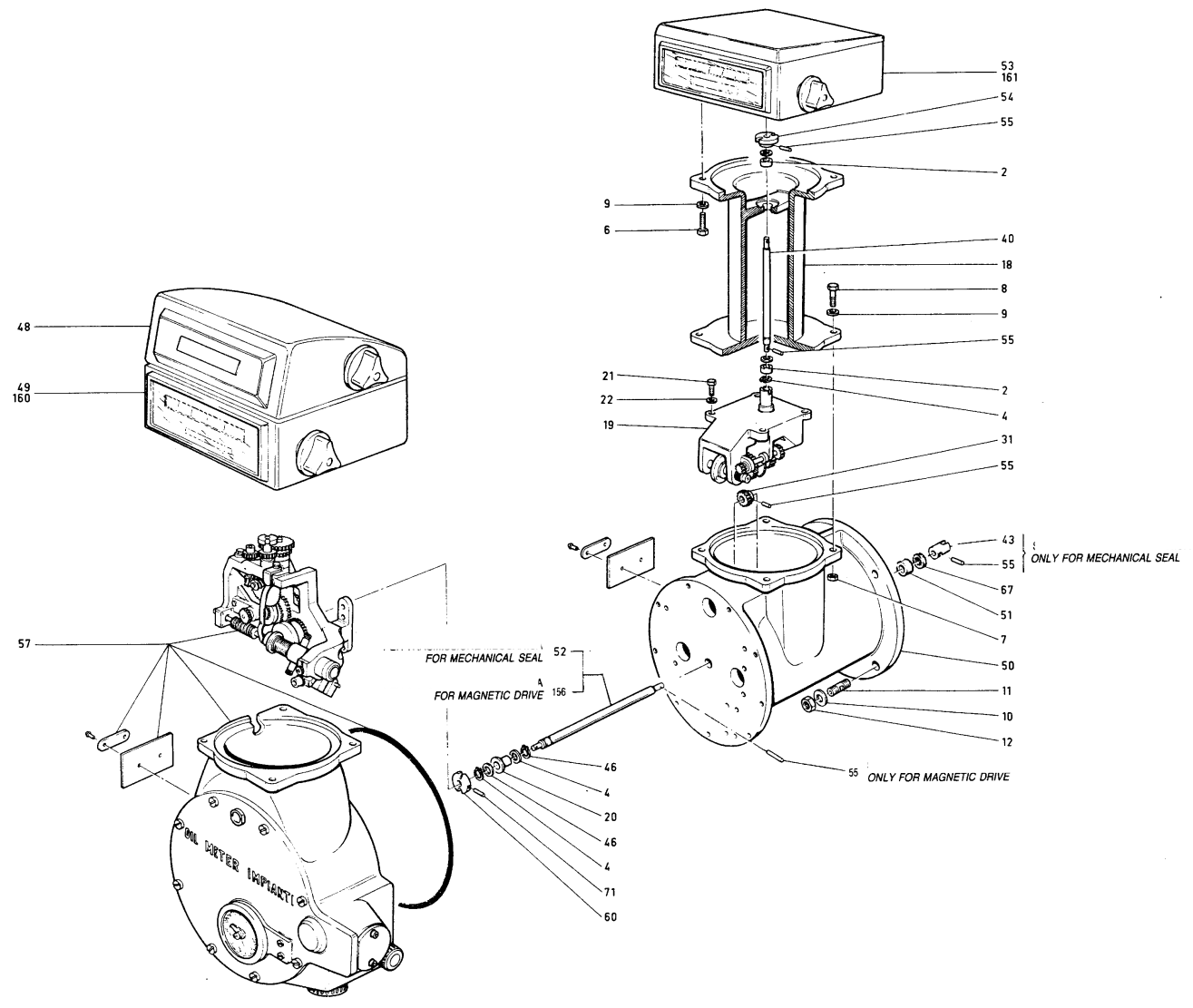

					SPACER AND TEMPERATURE COMPENSATOR FOR LBM 1000 - 3000					Dis.3290
item	N° CODE	DESCRIPTION	Q.ty	MATERIAL	item	N° CODE	DESCRIPTION	Q.ty	MATERIAL	
2	80BO1009	Bushes	2	Bronze	52	80AL0069	Shaft	1	Carbon steel	
4	80AN2036	Elastic ring	2	St. steel	53	81TE1003	Mechanical counter	1		
6	80VI9009	Screw	4	Carbon steel	54	80TR0012	Female coupling	1	Carbon steel	
7	80DA1099	Nut	4	Carbon steel	55	80SP5012	Spirol pin	4	Carbon steel	
8	80VI2081	Screw	4	Carbon steel	57	80CO2009	Temperature compens.	1		
9	80RO1204	Spring washer	4	Carbon steel	60	80TR0009	Female coupling	1	Carbon steel	
10	80RO1180	Spring washer	4	Carbon steel	67*	80AN1015	Lip seal ring	1	Rubber	
11	80PR3066	Stud	4	Carbon steel	71	80SP5024	Spirol pin	1	Carbon steel	
12	80DA1018	Nut	4	Carbon steel	156	80AL0024	Shaft	1	Carbon steel	
18	80PR4036	Extension	1	Aluminium	160	81PI1012	Gear plate	1		
19	80DI5006	Calibration mech.	1	Aluminium	161	81PI1006	Gear plate LBM 3000 LH	1		
20	80BO1012	Bush	1	Carbon steel	161	81PI1003	Gear plate LBM 3000 RH	1		
21	80VI2042	Screw	4	Carbon steel	161	81PI1012	Gear plate LBM 1000	1		
22	80RO1198	Spring washer	1	Carbon steel						
31	80VI3153	Gear	1	AISI 420						
40	80AL0030	Extension shaft	1	Carbon steel						
43	80MA1009	Female coupling	1	Carbon steel						
46	80RO1075	Washer	2	St. steel						
48	81ST1000	Accum. ticket printer	1							
48	81ST1003	Zero start ticket printer	1							
49	81TE1003	Mechanical counter	1							
50	80SC2021	Mechanism box	1	Aluminium						
51		Supplied with item 50	1		*Suggested spare parts					

T-3290.XLS

								Dis. 672/LBM	
CALIBRATION MECHANISM FOR LBM 1000-3000								Page 1 of 2	
item	N° CODE	DESCRIPTION	Q.ty	MATERIAL	item	N° CODE	DESCRIPTION	Q.ty	MATERIAL
1	80SC2000	Calibr.mechanism box	1	Aluminium	25	80AL0282	Drive shaft	1	Aisi 420
2	80VI2042	Support screw	4	Carbon steel	26	80RO1066	Washer	2	Carbon steel
3	80SU0012	Calibr.mech.support	1	Aluminium	27	80BO1009	Bush	1	Bronze
4	80AS0027	Friction wheel	1	Carbon steel	28*	80SP5009	Spirol pin	1	Carbon steel
5		Supplied with item 4			29	80IN3150	Z = 20 gear	1	St.steel
6*	80AS0129	Shaft with pinion	1	Carbon steel	30	80AL0270	Extension shaft	1	Carbon steel
7	80AS0258	Worm screw	1	Carbon steel	31	80AN2000	Circlip for shaft	1	Carbon steel
8*		Supplied with item 7			32	80PI5000	Bevel pinion	1	Carbon steel
9*	80CU1081	Bearing	2	St.steel	33		Supplied with item 17		
10	80VI4201	Screw	2	Carbon steel	34	80AS0084	Shaft/gear assy	1	Aisi 420
11	80TA1072	Oil discharge plug	1		35	80IN3165	Gear	1	Carbon steel
12	80TA1015	Oil charge plug	1		37		Supplied with item 34		
13	80VI5117	Screw	1	Carbon steel	38	80SP5009	Spirol pin	3	Carbon steel
14	80COB069	Calibrating cap	1	Aluminium	39	81IN0006	Oil level indicator	1	
15	80AN2018	Bearing circlip stop	1	Carbon steel	40	80MA1009	Transmission sleeve	1	Carbon steel
16	80RO1063	Washer	7	Carbon steel	41		Supplied with item 6		
17	80AS0069	Pinion assy	1	Carbon steel	42	80SP5000	Spirol pin	2	Carbon steel
19	80MO0228	Friction plate spring	1	Stainless steel	43	80RO1078	Wahser	2	Carbon steel
20	80PI1057	Friction plate	1	Carbon steel	44*	80GU1243	Gasket	1	Viton
21	80RO1042	Washer	1	Carbon steel	45	80AN2006	Circlip	1	Carbon steel
22*	80CU1045	Axial bearing	1	Carbon steel	46		Supplied with item 17		
23	80BO1000	Bush	2	Bronze	47	80BO1000	Bush	2	Bronze
24	80IN3234	Gear Z=66	1	Carbon steel	*Suggested spare parts				

		GEARING BOX FOR ELECTR. COUNTER VEGA MOUNTING						Dis. 3958	
								Page 1 of 1	
Q	N° CODE	DESCRIPTION	Q.ty	MATERIAL	item	N° CODE	DESCRIPTION	Q.ty	MATERIAL
1	80SC2030	Mechanism box	1	Aluminium	24	80IN3276	Gear	1	Carbon steel
2	80MA1009	Transmission coupling	1	Carbon steel	25	80SP5009	Spirol pin	1	Carbon steel
3	80SP5018	Spirol pin	1	Carbon steel	26	80AS0102	Entrainer	1	Carbon steel
4	80RO1078	Washer	4	Carbon steel					
5	80IN0006	Oil level indicator	1						
6	80SU0072	Mech.support for VEGA	1	Aluminium					
7	80BO1147	Bush	1	Bronze					
8	80AL0243	Shaft	1	St.steel					
9	80GR1093	Grain	1	St.steel					
10	80AN2006	Retaining ring	2	Carbon steel					
11	80AL0246	Shaft	1	St. steel					
12	80AN2000	Retaining ring	1	Carbon steel					
13	80TA1072	Oil discharge plug	1						
14	80BO1099	Bush	1	Bronze					
15	80RO1066	Washer	2	Carbon steel					
16	80VI2042	Screw	4	Carbon steel					
17	80RO1033	Exernal washer	4	Carbon steel					
18	80TA1015	Oil charge plug	1						
19	80GU0207	Gasket	1						
20	80VI5117	Screw	1	Carbon steel					
21	80COB069	Calibr.inlet cover	1	Aluminium					
22	80VI8048	Vite Screw	2	Carbon steel					
23	80IN3279	Gear	1	Carbon steel					

T-3958.XLS