

CONTOIL® DFM



Table of contents

Safety instructions	2		
- Designed use			
- Installation, commissioning and operation			
- Operational safety			
- Return of the instruments			
- Notes on safety conventions and icons			
Configuration overview	3		
- Schematic of a configuration			
- Installation Advices			
- For your Security...			
How to connect the...	4		
- Double Flow-Sensor to the Board Computer (DFM 8D to the DFM-BC)			
- Single Flow-Sensors to the Board Computer (DFM 8S / 20S / 25S to the DFM-BC)	5		
- Single Flow-Sensors to the Board Computer for direct fuel consumption	7		
- Board Computer (DFM-BC) to a Fleet Manager or GPS Tracking System	8		
- Flow-Sensors to other Fuel Counter than the DFM Board Computer (DFM 8D / 8S / 20S / 25S)	9		
Startup (commissioning)	10		
Operating Instruction for the Board Computer (DFM-BC)	11		
- For User ... daily information (User Mode)			
- Total Consumption			
- TRIP			
- Reset the TRIP			
- Consumption			
- Display Test			
- For Managers ... more and deeper information (Manager Mode)			
- Entering the Info Mode			
- Configuration (Information about Sensor Type, RL Sensor, User Reset)			
- Supply Line (information about Total, TRIP, Current I/h, Op. Hours)			
- Return Line (information about Total, TRIP, Current I/h, Op. Hours)			
- Consumption Overview (results from Supply Line minus Return Line)			
- Supply Configuration			
- Return Configuration			
- Error Log Entry			
- Error Log			
- Config Log Entry			
- Config Log			
- Clock			
- Factory Data			
		For Service Peoples ... parameter setting (Service Mode)	
		- Entering the Service Mode	
		- Entry Code	
		- Configuration (Sensor Type, Return Line Sensor, User Reset, AUX)	
		- Supply Line (Total, TRIP, Current)	
		- Return Line (Total, TRIP, Current)	
		- Consumption Overview (Total, TRIP, Consumption)	
		- Supply Configuration (SL KF, SL app, Qmax)	
		- Return Configuration (SL KF, SL app, Qmax)	
		- Error Log Entry	
		- Read the stored Error Messages (Error Log)	
		- Config Log Entry	
		- Read the stored Config Messages (Config Log Entry)	
		- Clock	
		- Factory Data	
		Error condition	18
		- Error Messages	
		- Description of the Error Messages.	
		Higher Performance Results (with application optimization)	20
		What do if it is not functioning?	20
		- No Display on the Board Computer (DFM-BC).	
		- The Board Computer (DFM-BC) is running, but no value from the Sensors.	
		- After Installation, an <Error> is displayed.	
		Electrical Connections and Specifications	21
		- For the DFM-8D	
		- For the DFM 8S / 20S / 25S	
		- For the DFM-BC	
		Electrical scheme of the DFM Systems	23
		Specification and Technical Data	25
		Dimensions	26
		- DFM-8S	
		- DFM-8D	
		- Flow-Sensors DFM 20S and DFM 25S	
		- DFM-BC	
		Ordering Information	28
		Warranty Information	28

Safety instructions

Designed use

This unit is designed for acquisition, calculation, displaying and sending data. Resulting from incorrect use or from use other than that designated, can suspend the operational safety of the devices. The manufacturer accepts no liability for damages being produced from this.

Installation, commissioning and operation

Installation, connection to the electricity supply, commissioning and maintenance of the device must be carried out by trained, qualified specialists authorised to perform such works. The specialist must have read and understood these Operating Instructions and must follow the instructions they contain. The installer must ensure that the measuring system is correctly wired in accordance with the wiring diagrams. Before working on electrical installation, make sure to disconnect the power supply and ensure that nobody can reconnect it without your permission.

Pay attention to the following points:

- Voltage, operation data
- Maximum transmission length
- Cable cross section, length
- Ambient temperature and mounting position

Operational safety

The manufacturer reserves the right to modify technical data without prior notice. Your local distributor will supply you with current information and updates to these Operating Instructions.

Return of the instruments

The following procedures must be carried out before a device requiring repair or calibration, for example, is returned to Aquametro:

- Always enclose a fully completed "Repair Form" with the device. Only then Aquametro can transport, examine and repair a returned device.

Notes on safety conventions and icons

The devices are designed to meet state-of-the-art safety requirements. They have been tested and left the factory in a condition in which they are safe to operate. They can, however, be a source of danger if used incorrectly or for use other than the designated use. Consequently, always pay particular attention to the safety instructions indicated in these instructions by the following symbols:



Warning!

"Warning" indicates an action or procedure which, if not performed correctly, can result in injury or a safety hazard. Comply strictly with the instructions and proceed with care.



Caution!

"Caution" indicates an action or procedure which, if not performed correctly, can result in incorrect operation or destruction of the device. Comply strictly with the instructions.



Note!

"Note" indicates an action or procedure which, if not performed correctly, can have an indirect effect on operation or trigger an unexpected response on the part of the device.

Configuration overview

Schematic of a configuration

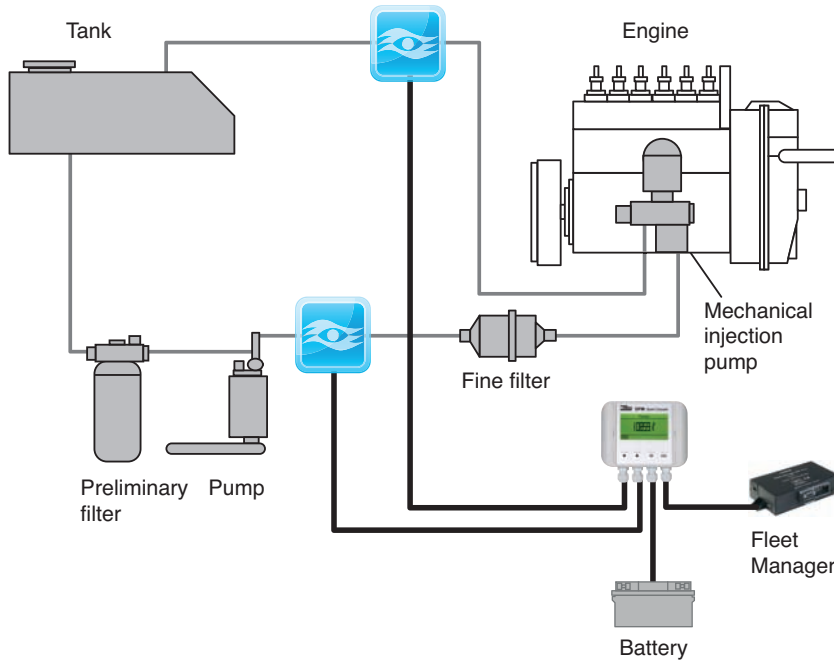

The 2 sensor meter are just an example. They can be changed with a compact one.

Installation Advices

- The sensors have to be always protected by a fuel filter. The max. mesh size depends on the sensor size. The original truck filter is ideal for all sensor sizes.
- Be aware, that all the fuel which is passing through the supply line sensor AND is not consumed by the engine, MUST return through the return line sensor to the tank.
- A leak line of the injector MUST be returned on the return line and before the return flow meter
- If the sensors are marked with S and R, install the S-sensor in the SUPPLY and the R-sensor in the RETURN pipe.
- The arrow on the sensors must be show in the flow direction.
- The sensors must be absolutely free of gas inclusions.
- High pressure hammers from injection pump have to be avoided on flow sensors (for example, with a min. 2 meter wounded hose between sensor meter on the supply line and the injection pump).
- Install the DFM-BC on the cabin floor, on the car dashboard or on the cabin top; but always in good readable and accessible position.
- For a good and professional installation of the Board Computer (DFM-BC) we recommend the Mounting Bracket Kit (part no. 80485)

For your Security...



- DO NOT program or change parameters while you drive. This is / may be dangerous for you and the other traffic participants.
- During the electrical installation disconnect the vehicle battery.
- Be careful when disconnecting the pipes (exit of fuel will occur).
- After installation check all pipes for leaks.

How connect the...



Before you start with the electrical connection of the system, you must have done a correct installation of the delivered components. This installation must be done by an authorized and certified company/person.
Please be aware: an incorrect installation may destroy the DFM-System and damage your vehicle. In this case, Aqua-metro will deny all responsibilities.

Double Flow-Sensor to the Board Computer (DFM 8D to the DFM-BC)



Please read the **Installation Tips** before you start.

1. With the DFM-BC in front of you, open the side-wings of the box and unscrew the 4 screws. Put the upper part of the DFM-System careful by side. The upper part is connected to the base part with a flat cable.
2. Look at the print on the base. You will see a connector with 14 positions.
3. Take the cable from the DFM-8D and pass it through one of the gland of the DFM-BC. Tight very well by hand the gland-nut, until the cable is fixed.
4. Now connect the wires from the DFM-8D according to the table below to the connector on the DFM-BC print:

DFM-8D - cable colors		DFM-BC - positions on the connector
Black	to	1
Brown	to	2
Yellow	to	3
Green	to	4
Red	to	5
White	to	6



To ensure a proper function, the cable, described in the procedure below, **must be** connected direct to the vehicle battery. Do not connect it over the start-key of the vehicle. That means, also with the vehicle key in your pocket the DFM-BC must be electrical powered. The consumption of the electrical power is far below 1mA.

5. Connect a two wire cable (0.75 mm²) from the vehicle battery, through one of the gland of the DFM-BC, to the connector position 13 (batt. plus) and position 14 (batt. minus). Tight very well by hand the gland-nut, until the cable is fixed.
6. After all cables are connected and well in place, put the upper part of the DFM-BC on the base part and screw it down.
7. Look at the type plate of the DFM-8D Sensor Meter. Read the value for the SL-KF and the RL-KF (it must be a value like **SL KF +0.12 or SL KF -0.13**). Keep this value in mind or write it down to paper.
These values are needed to reach optimal performance.
8. Take the DFM-BC. If it is off, press one of the 4 Keys on the front to reactivate it.
Go to the menu point <Service>.
Press <OK> and enter the Service-Code. Standard service code is: 1111.
9. Input Value and Output Value:
Change the "Input Value" by doing the following:
 - a. Press the ▼ down-arrow
 - b. On the "Input" line press <OK>
 - c. The field "Input xxxx.x ml" will be highlighted.
 - d. "Move the cursor to the right with the <OK> key, move the cursor to the left with the <ESC> key.
 - e. Press the ▼ down-arrow or the ▲ up-arrow to adjust the "Input Value" to 12.5 ml/pulse.
 - f. Press <OK> to confirm the modification.
 - g. The "Output Value" can be chosen from the "Sensor Type" table or set a value of your choice.

Sensor Type	Input Value
DFM-8S	12.5 ml
DFM-20S	36 ml
DFM-25S	100 ml

10. Set the Return Line Sensor
 - a. Press the ▼ down-arrow to move to the <RL Sensor> line.
 - b. The value must be <Yes> (standard). If not, press the <OK> key and change the value with the arrows key.

11. Set the <SL KF> and the <SL app>.
 - a. Starting from the previous position, press many time the ▼ down-arrow, until you reach the menu point "Supply configuration".
 - b. Press <OK> at the menu point "SL KF". Enter the value for the <SL KF> using the arrow keys. This value is printed on the type plate of the flow meter. Confirm with <OK>.
 - c. Move with <OK> to the menu point <SL app>. Normaly you do not need to change this value. For more information go to the section <Higher Performance Results>
 - d. Press many times the ▼ down-arrow key until you reach the menu point "Return configuration".
 - e. Press <OK> at the menu point "RL KF". Enter the value for the <RL KF> using the arrow keys. This value is printed on the type plate of the flow meter. Confirm with <OK>.
 - f. Move with <OK> to the menu point <SL app>. Normaly you do not need to change this value. For more information go to the section <Higher Performance Results>
12. Set the date
 - a. Starting from the previous position, press many time the ▼ down-arrow, until you reach the menu point "Clock".
 - b. On the line "Date", press <OK>. Modify the date by using the ▼ down-arrow or the ▲ up-arrow. Move from left to right with the <OK> key.
 - c. When the date is set, confirm it with the <OK> key.
13. Set the time
 - a. Move with the ▼ down-arrow key to the line "Time".
 - b. On the line "Time", press <OK>. Modify the time by using the ▼ down-arrow or the ▲ up-arrow. Move from left to right with the <OK> key
 - c. When the time is set, confirm it with the <OK> key.
14. Set the Service code.

This procedure is optional. We recommend to change it for more security.
Store the new service code in a save place. Loosing of the service code leads to a "factory reset", which means sending the DFM-BC to the factory with loosing of all setting parameters. So, be careful.

 - a. Move with the ▼ down-arrow key to the line "Service code".
 - b. On the line "Service code", press <OK>. Modify the service code by using the ▼ down-arrow or the ▲ up-arrow. Move from left to right with the <OK> key and from right to left with the <ESC> key.
 - c. When the new service code is set, confirm it with the <OK> key.
15. End of installation
 - a. Exit with <ESC>.
 - b. After the installation is done **and before** you start the engine, go to the section "Startup (commissioning)" for the initial checks and startup.



Single Flow-Sensors to the Board Computer (DFM 8S / 20S / 25S to the DFM-BC)



This installation consists always in pair installation of the Sensor Meters.
For an easier reading during this section the DFM 8S / 20S / 25S are called **DFM Sensor**.

Please read the **Installation Advices** before you start.

1. With the DFM-BC in front of you, open the side-wings of the box and unscrew the 4 screws. Put the upper part of the DFM-System careful by side. The upper part is connected to the base part with a flat cable.
2. Look at the print on the base. You will see a connector with 14 positions.
3. Take the cable from the first DFM-Sensor and pass it through one of the gland of the DFM-BC. Do the same with the second one. Tight very well by hand the gland-nut, until the cable is fixed.
4. Now connect the wires from the DFM-Sensor according to the table below to the connector on the DFM-BC print:

Supply-Line Sensor

DFM-Sensor - cable colors		DFM-BC - positions on the connector
Black	to	1
Brown	to	2
Yellow	to	3
Green	to	4
Red	to	Not used
White	to	Not used

Return-Line Sensor

DFM-Sensor - cable colors		DFM-BC - positions on the connector
Black	to	7
Brown	to	8
Yellow	to	9
Green	to	10
Red	to	Not used
White	to	Not used



5. To ensure a proper function, the cable, described in the procedure below, **must be** connected direct to the vehicle battery. That means, also with the vehicle key in your pocket the DFM-BC must be electrical powered. The consumption of the electrical power is far below 1mA.

Connect a two wire cable (0.75 mm²) from the vehicle battery, through one of the gland of the DFM-BC, to the connector position 13 (Batt. plus) and position 14 (Batt. minus). Tight very well by hand the gland-nut, until the cable is fixed.



6. After all cables are connected and well in place, put the upper part of the DFM-BC on the base part and screw it down.

7. Look at the type plate of the DFM-Sensor Meter. Read the value for the SL-KF and the RL-KF (example: it must be a value like **<SL KF +0.12>** or **<SL KF -0.13>**). Keep this value in mind or write it down to a paper. These values are needed to reach optimal performance.

8. Take the DFM-BC. If it is off, press one of the 4 Keys on the front to reactivate it.

Go to the menu point **<Service>**. Press **<OK>** and enter the Service-Code.

Standard service code is: 1111.

9. Input Value and Output Value

Change the "Input Value" by doing the following:

- Press the ▼ down-arrow
- On the "Input" line press **<OK>**
- The field "Input xxx.x ml" will be highlighted.
- Press the ▼ down-arrow or the ▲ up-arrow to adjust the "Input Value" according to the table "Sensor Type"
- Press **<OK>** to confirm the modification.
- The "Output Value" can be chosen from the "Sensor Type" table or set a value of your choice.



Sensor Type	Input Value
DFM-8S	12.5 ml
DFM-20S	36 ml
DFM-25S	100 ml

10. Set the Return Line Sensor

- Press the ▼ down-arrow to move to the **<RL Sensor>** line.
- The value must be **<Yes>** (standard). If not, press the **<OK>** key and change the value with the arrows key.

11. Set the **<SL KF>** and the **<SL app>**.

- Starting from the previous position, press many time the ▼ down-arrow, until you reach the menu point "Supply configuration".
- Press **<OK>** at the menu point "SL KF". Enter the value for the **<SL KF>** using the arrow keys. This value is printed on the type plate of the flow meter. Confirm with **<OK>**.
- Move with **<OK>** to the menu point **<SL app>**. Normally you do not need to change this value. For more information go to the section **<Higher Performance Results>**.
- Press many times the ▼ down-arrow key until you reach the menu point "Return configuration".
- Press **<OK>** at the menu point "RL KF". Enter the value for the **<RL KF>** using the arrow keys. This value is printed on the type plate of the flow meter. Confirm with **<OK>**.
- Move with **<OK>** to the menu point **<SL app>**. Normally you do not need to change this value. For more information go to the section **<Higher Performance Results>**

12. Set the date

- Starting from the previous position, press many time the ▼ down-arrow, until you reach the menu point "Clock".
- On the line "Date", press **<OK>**. Modify the date by using the ▼ down-arrow or the ▲ up-arrow. Move from left to right with the **<OK>** key and from right to left with the **<ESC>** key.
- When the date is set, confirm it with the **<OK>** key.

13. Set the time
 - a. Move with the ▼ down-arrow key to the line "Time".
 - b. On the line "Time", press <OK>. Modify the time by using the ▼ down-arrow or the ▲ up-arrow. Move from left to right with the <OK> key and from right to left with the <ESC> key.
 - c. When the time is set, confirm it with the <OK> key.
14. Set the Service code

This procedure is optional. We recommend changing for more security.
Store the new service code in a save place. Loosing of the service code leads to a "factory reset", which means sending the DFM-BC to the factory with loosing of all setting parameters. So, be careful.

 - a. Move with the ▼ down-arrow key to the line "Service code".
 - b. On the line "Service code", press <OK>. Modify the service code by using the ▼ down-arrow or the ▲ up-arrow. Move from left to right with the <OK> key and from right to left with the <ESC> key.
 - c. When the new service code is set, confirm it with the <OK> key.
15. End of installation
 - a. Exit with <ESC>.
 - b. After the installation is done **and before** you start the engine, go to the section "Startup (commissioning)" for the initial checks and startup.



Single Flow-Sensors to the Board Computer for direct fuel consumption (DFM 8S / 20S / 25S to the DFM-BC)



This installation is done with a single installation of the Sensor Meters. For an easier reading during this section the DFM-8S / 20S / 25S are called **DFM Sensor**.

Please read the **Installation Advices** before you start.

1. With the DFM-BC in front of you, open the side-wings of the box and unscrew the 4 screws. Put the upper part of the DFM-System gently by side. Be CAREFULL. The upper part is connected to the base part with a flat cable.
2. Look at the print on the base. You will see a connector with 14 positions.
3. Take the cable from the DFM-Sensor and pass it through one of the gland of the DFM-BC. Tight very well by hand the gland-nut, until the cable is fixed.
4. Now connect the wires from the DFM-Sensor according to the table below to the connector on the DFM-BC print:

DFM-Sensor - cable colors		DFM-BC - positions on the connector
Black	to	1
Brown	to	2
Yellow	to	3
Green	to	4
Red	to	Not used
White	to	Not used

5. To ensure a proper function, the cable, described in the procedure below, **must be** connected direct to the vehicle battery. That means, also with the vehicle key in your pocket the DFM-BC must be electrical powered. The consumption of the electrical power is far below 1mA.
Connect a two wire cable (0.75 mm²) from the vehicle battery, through one of the gland of the DFM-BC, to the connector position 13 (Batt. plus) and position 14 (Batt. minus). Tight very well by hand the gland-nut, until the cable is fixed.
6. After all cables are connected and well in place, put the upper part of the DFM-BC on the base part and screw it down.
7. Look at the type plate of the DFM-Sensor Meter. Read the value for the SL-KF (example: it must be a value like <SL KF +0.12> or <SL KF -0.13>). Keep this value in mind or write it down to a paper.
These values are needed to reach optimal performance.
8. Take the DFM-BC. If it is off, press one of the 4 Keys on the front to reactivate it.
Go to the menu point <Service>. Press <OK> and enter the Service-Code.
Standard service code is: 1111.



9. Input Value and Output Value
Change the "Input Value" by doing the following:
 - a. Press the ▼ down-arrow
 - b. On the "Input" line press <OK>
 - c. The field "Input xxx.x ml" will be highlighted.
 - d. Press the ▼ down-arrow or the ▲ up-arrow to adjust the "Input Value" according to the table "Sensor Type"
 - e. Press <OK> to confirm the modification.
 - f. The "Output Value" can be chosen from the "Sensor Type" table or set a value of your choice.

Sensor Type	Input Value
DFM-8S	12.5 ml
DFM-20S	36 ml
DFM-25S	100 ml

10. Set the Return Line Sensor
 - a. Press the ▼ down-arrow to move to the <RL Sensor> line.
 - b. **This value must be <No>**. If it is not, press the <OK> key and change the value with the arrows key.
11. Set the <SL KF> and the <SL app>.
 - a. Starting from the previous position, press many times the ▼ down-arrow, until you reach the menu point "Supply configuration".
 - b. Press <OK> at the menu point "SL KF". Enter the value for the <SL KF> using the arrow keys. This value is printed on the type plate of the flow meter. Confirm with <OK>.
 - c. Move with <OK> to the menu point <SL app>. Normally you do not need to change this value. For more information go to the section <Higher Performance Results>
 - d. Press many times the ▼ down-arrow key until you reach the menu point "Return configuration".
 - e. Press <OK> at the menu point "RL KF". Enter the value for the <RL KF> using the arrow keys. This value is printed on the type plate of the flow meter. Confirm with <OK>.
 - f. Move with <OK> to the menu point <SL app>. Normally you do not need to change this value. For more information go to the section <Higher Performance Results>
12. Set the date
 - a. Starting from the previous position, press many times the ▼ down-arrow, until you reach the menu point "Clock".
 - b. On the line "Date", press <OK>. Modify the date by using the ▼ down-arrow or the ▲ up-arrow. Move from left to right with the <OK> key and from right to left with the <ESC> key.
 - c. When the date is set, confirm it with the <OK> key.
13. Set the time
 - a. Move with the ▼ down-arrow key to the line "Time".
 - b. On the line "Time", press <OK>. Modify the time by using the ▼ down-arrow or the ▲ up-arrow. Move from left to right with the <OK> key and from right to left with the <ESC> key.
 - c. When the time is set, confirm it with the <OK> key.
14. Set the Service code
This procedure is optional. We recommend changing for more security.
Store the new service code in a safe place. Loosing of the service code leads to a "factory reset", which means sending the DFM-BC to the factory with loosing of all setting parameters. So, be careful.
 - a. Move with the ▼ down-arrow key to the line "Service code".
 - b. On the line "Service code", press <OK>. Modify the service code by using the ▼ down-arrow or the ▲ up-arrow. Move from left to right with the <OK> key and from right to left with the <ESC> key.
 - c. When the new service code is set, confirm it with the <OK> key.
15. End of installation
 - a. Exit with <ESC>.
 - b. After the installation is done **and before** you start the engine, go to the section "Startup (commissioning)" for the initial checks and startup.



Board Computer (DFM-BC) to a Fleet Manager or GPS Tracking System



For an easier reading during this section the Fleet Manager or the GPS Tracking-System are called Auxiliary.

This configuration allows you to send the exactly calculated consumption amount to an external device (e.g., Fleet Manager or GPS Tracking System). In order to work, a flow meter with the correct "Output Value" must be installed on the DFM-BC



1. With the DFM-BC in front of you, open the side-wings of the box and unscrew the 4 screws. Put the upper part of the DFM-System gently by side. Be CAREFULL. The upper part is connected to the base part with a flat cable.
2. Look at the print on the base. You will see a connector with 14 positions.
To ensure a proper function, this cable **must be** connected direct to the vehicle battery. Do not connect it over the start-key of the vehicle. That means, also with the vehicle key in your pocket the DFM-BC must be electrical powered. The consumption of the electrical power is far below 1mA.
3. Connect a two wire cable (0.75 mm²) from the vehicle battery, through one of the gland, to the position 13 (Batt. plus) and position 14 (Batt. minus). Tight very well by hand the gland-nut, until the cable is fixed.
To ensure a proper function, this cable must have a direct connection to the battery. Do not connect it over the start-key of the vehicle.
4. Take the cable from the Auxiliary and pass it through one of the gland of the DFM-BC. Tight very well by hand the gland-nut, until the cable is fixed.
5. Connect the cable according to the table below:

DFM-BC positions on the connector		Fleet-Manager or GPS Tracking-System
11 (Signal Output)	to	Signal or Digital/Analog Input
12 (Ground)	to	Ground

For more information see section "Electrical connections and Specifications"



6. After all cables are connected and well in place, put the upper part of the DFM-BC on the base part and screw it down.
7. Take the DFM-BC. If it is off, press one of the 4 Keys on the front to reactivate it. Go to the menu point <Service>. Press <OK> and enter the Service-Code. Standard service code is: 1111.
8. Set the Auxiliary (AUX) active.
 - a. Press the ▼ down-arrow to move to the <AUX> line.
 - b. On the line "AUX", press <OK>. Modify the value by using the ▼ down-arrow or the ▲ up-arrow.
 - c. Change the value to <Yes>
 - d. Press <OK> to confirm the modification.
 - e. Exit with <ESC>.
9. From this point the signal will be send to the auxiliary port of the DFM-BC and the word AUX will be displayed on the DFM-BC Display in big letters. No more information on the DFM-BC screen will be available until you deactivate the <AUX>.
10. Set the Fleet-Manager or the GPS-System input according to the "Output Value" set during the installation of the flow meters.

Flow-Sensors to other Fuel Counter than the DFM Board Computer (DFM 8D / 8S / 20S / 25S)

1. Go to section <Electrical Connections and Specifications> and install the DFM Sensors according to the specification of the used Fuel Counter.
2. Go to the section "Startup (commissioning)"

DFM-BC connection to other flow meter(s) than the DFM flow meter(s).

For differential measurement

Supply Line flow meter

1. Connect the "Signal" cable from the flow meter 1 to the pin 3 of the DFM-BC
2. Connect the "Ground" cable from the flow meter 1 to the pin 2 of the DFM-BC

Return Line flow meter

3. Connect the "Signal" cable from the flow meter 2 to the pin 9 of the DFM-BC
4. Connect the "Ground" cable from the flow meter 2 to the pin 8 of the DFM-BC



For direct measurement

1. Connect the "Signal" cable from the flow meter to the pin 3 of the DFM-BC
2. Connect the "Ground" cable from the flow meter 1 to the pin 2 of the DFM-BC

Setting of the DFM-BC

Start with the settings of the DFM-BC by doing the following:

1. Take the DFM-BC. If it is off, press one of the 4 Keys on the front to reactivate it.
Go to the menu point <Service>. Press <OK> and enter the Service-Code
Standard service code is: 1111
2. On the "Input Value" line press <OK>
3. The field "xxx ml/p" will be highlighted.
4. Move the cursor to the right with the <OK> key, move the cursor to the left with the <ESC> key
5. Press the ▼ down-arrow or the ▲ up-arrow to adjust the "Input Value" according to the flow meter signal value.
6. Press <OK> to confirm the modification.
7. Repeat the above procedure for the "Output Value" (set the "Output Value" requested by your external device (GPS or Fleet Manager)
8. Set the Return Line Sensor
 - a. Press the ▼ down-arrow to move to the <RL Sensor> line.
 - b. **Differential measurement:** this value must be set to <Yes>. If it is not, press the <OK> key and change the value with the arrows key.
 - c. **Direct measurement:** this value must be set to <No>. If it is not, press the <OK> key and change the value with the arrows key
9. Go to the section "Startup (Commissioning)".

Startup (commissioning)



In this section we assume that the installation of all needed instruments has been done in a correct and professional way, that means,

The fuel system is purged according to the engine manufacturer's advice, leak and bubble free.

If this is not the case, please set the system in proper operating condition.

1. Start the engine and let it run at min. load until it reached its operating conditions (heat exchange water between 70 °C - 90 °C)
2. Check all connections for leak proof.



The next steps are only for user which has a DFM Board Computer (DFM-BC). If you have not a DFM Board Computer you can skip this section

3. Switch on the **Board Computer** (DFM-BC) by touching a key.
4. Go to the **Info** mode, by using the ▼ down-arrow or the ▲ up-arrow, and press <OK>.
5. Check on the <Configuration> display for the correct values.
 - a. Check the <Input / Output Value> and the <RL Sensor>. Are these settings correct?
 - b. If not, go back to the section <How to connect ...> and take the appropriate corrections.
6. Go to the <Supply Line>
 - a. The values for **Total**, **TRIP** and **Current** must show values higher than zero.
7. Go to the <Return Line> (**ONLY** for differential measurement)
 - a. The values for **Total**, **TRIP** and **Current** must show values higher than zero.
8. Go to the <Consumption Overview>
 - a. The values for **Total** and **TRIP** must show values higher than zero and must change during the run, that means, the value has to rise up.
 - b. The value for Consumption depends on the engine size and its fuel consumption, but must still be higher than zero. As long as the engine runs in low load mode, this value must always show the same amount (small variations behind the comma are normal)

9. Go to the <Supply Configuration>
 - a. Check the <SL KF>. Is it the right one?
 - b. If not, go back to the section <How to connect ...> and take the appropriate corrections.
10. Go to the <Return Configuration>
 - a. Check the <RL KF>. Is it the right one?
 - b. If not, go back to the section <How to connect ...> and take the appropriate corrections.

Operating Instruction for the Board Computer (DFM-BC)



The Board Computer (DFM-BC) has no ON/OFF switch. It has a sleep mode.

What does it mean?

When no activities are recognized on the connected lines (Supply line and Return Line) the Board Computer (DFM-BC) will switch OFF itself. It will be waked up when about 2 pulses are coming in over the connected lines.

The consumed voltage is very slow (less than 1 mA), so that no discharge of the battery can occur during a very long period.

The Menu structure has 3 branches:

- **User-Mode**

Is intended for the daily user. It informs him about the daily needed information.

- **Manager-Mode**

Is intended for the advanced user. It shows you deeper information about the DFM-System. No parameter changes are possible.

- **Service-Mode.**

Service-Mode is only for the Service-Engineer and is password protected. Because it give you complete access to all parameters, it is absolutely important to be a trained and qualified person. Inaccurate changes in this section can result in fault calculations and mistakes.

For User ... daily information (User Mode)

Total Consumption



This picture shows the total consumption of the Engine since commissioning.

▲ Last screen ▼ Next screen

TRIP



This picture shows the consumption of the Engine since the last reset.

▲ Previous screen ▼ Next screen

Reset the TRIP



Press OK to enter reset mode

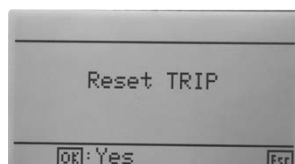

Press OK to again to reset the TRIP

After this, the TRIP will show 0 l/h

Consumption



This picture shows the current consumption of the Engine in l/h.

▲ Previous screen ▼ Next screen



The next two screens (Info Mode and Service Mode) are explained in the section **For Managers** and **For Service People**.

Display Test



Press OK to start the Display test.

▲ Previous screen ▼ Next screen

This will start the Display test. The screen will switch from a black screen to a blank screen and back. At the end of the test it will go to the "Total screen".

During the switching from black to blank, have a look at the surface for missing pixels (points). If you saw missing pixel, then the display must be changed (use the Repair Form). If you do not have one, contact your local dealer.

For Managers ... more and deeper information (Manager Mode)



Take a few minutes to read first the section **User Mode**. It is the base for the next section. In the manager mode you have all the relevant DFM-System information at a glance.



1. From the **User Mode** go with the ▲ arrows or ▼ arrows to the Info screen and press OK. After you entered the Info screen, the
2. **ESC** key has always the same function: it brings you back one step (to the Info Mode).
3. **▲ arrow** brings you to the previous screen or to the line above
4. **▼ arrow** brings you to the next screen or to the next line

In the following sections, the **ESC** key, **▲ arrow** and the **▼ arrow** will be no more described.

Entering the Info Mode

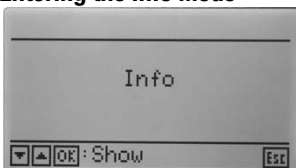

Press OK to enter the Info mode

Be aware: NO changes are possible in the Info Mode. This is just intended for Information.

Configuration (Information about Input / Output Value, RL Sensor, User Reset)

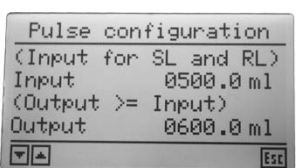

Input: value of the incoming signal in ml/pulse

Output: value of the outgoing signal. This value should not be lower than the "Input Value"



RL sensor: is a Return Line Sensor installed? (Yes / No)

User reset: it is allowed for the user to do a reset? (Yes / No)

Aux: communication line to an external device (e.g, Fleet Manager, GPS-Tracking system)

Be aware: the Return Line flow meter must be always the same like the Supply Line sensor

Supply Line (information about Total, TRIP, Current l/h, Op. Hours)

Supply line	
Total	35201.2 l
TRIP	35201.2 l
Current	225.0 l/h
Op.hours	4.7 h

Total: amount of liter that has flew through this sensor since the commissioning
TRIP: amount of liter since the last reset (it functions like a daily counter)
Current: actually flow rate in l/h
Op. hours: operation hours of the sensor since commissioning

Return Line (information about Total, TRIP, Current l/h, Op. Hours)

Return line	
Total	24208.7 l
TRIP	24208.7 l
Current	180.0 l/h
Op.hours	4.9 h

Total: amount of liter that has flew through this sensor since the commissioning
TRIP: amount of liter since the last reset (it functions like a daily counter)
Current: actually flow rate in l/h
Op. hours: operation hours of the sensor since commissioning

Consumption Overview (results from Supply Line minus Return Line)

Consumption overview	
Total	12360.7 l
TRIP	690.5 l
Current	90.0 l/h

Total: Engine consumption since the commission.
TRIP: Engine consumption since the last reset.
Current: Current engine consumption.

Supply Configuration

Supply configuration	
SL K'F	+0.00
SL app	+0.00
Qmax	9503.1 l/h

SL K'F: Optimization value for best sensor performance.
SL app: Optimization value for best application performance.
Qmax: this value shows you how high was the flow rate peak you ever had in the supply line since the commissioning.

Return Configuration

Return configuration	
RL K'F	+0.00
RL app	+0.00
Qmax	17200.0 l/h

RL cal: Optimization value for best sensor performance.
RL app: correction value for the consumption calculation (typical: fuel temp, etc.)
Qmax: this value shows you how high was the flow peak you ever had in the return line since the commissioning.

Error Log Entry

The DFM-BC is able to catch different sensor conditions, to compare it with stored value and to decide if an error occurs or not. If an error occurs, it will be showed on the display and stored in an Error Log for later reviewing. This information will help you in resolving complex situation. If the allowed Error Log entries are exceeded, the oldest one will be deleted.

Error log entry	
Last log at	
2008-01-01 04:52:04	

This screen shows you, when the last error messages was recorded.

Press OK to enter the Error Log

Error Log

This screen shows you, with data and time stamp, the last stored Error Messages in a readable form.

Error log	
2008-01-01 00:03:38	
S<R	

Press the ▲ ▼ arrows to go through the messages.
 If you press the ▲ arrow by the first message you will be leaded to the last message.
 If you press the ▼ arrow by the last message you will be leaded to the first message.
 For more explanations see section "Description of the Error Messages".

Config Log Entry

The DFM-BC has the ability to store all configuration changes which happened. If the allowed entries are exceeded, the oldest one will be deleted.

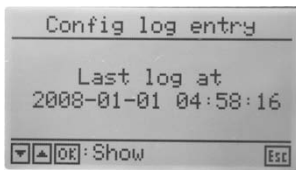

This screen shows you, when the last configuration change was recorded.

Press OK to enter the Config Log.

Config Log

This screen shows you, with data and time stamp, the last stored configuration change in a readable way.



Press the ▲ ▼ arrows to go through the messages.

If you press the ▲ arrow by the first message you will be led to the last message.

If you press the ▼ arrow by the last message you will be led to the first message.

The messages are user readable, so there are no need for more explanations.

Clock

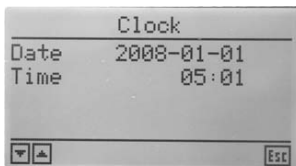

This screen shows you the date and the time.

Factory Data

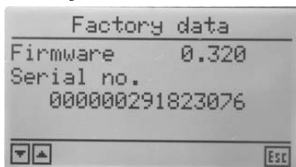

This screen shows you the firmware version and the serial number of the DFM-BC

For Service Peoples ... parameter setting (Service Mode)

In this section we assume that the service engineer is familiarly with the differential measurement technique and also knows the precedent sections. In the Service Engineer mode you have unrestricted access to all vital parameter. Please be careful in changing parameter. Inadequate parameter settings can lead to incorrect functions and calculations.



A good way to avoid mistakes is to write down the parameters **before** you change it.



1. From the **User Mode** go with the ▲ arrow or ▼ arrow to the **Service** screen and press OK. After you entered the Service branches, the
2. **ESC** key
 - a. brings you back **one step** or
 - b. brings you back **one digit** (one position).
3. **OK** key
 - a. Means **Modify, Show, Store, Reset, Yes, Next**. All this are described on the display of the Board Computer (DFM-BC)
4. **▲arrow** key
 - a. brings you to the **previews screen** or **to the line above** or
 - b. it is used to change values (increment).
5. **▼arrow** key
 - a. brings you to the **next screen** or **to the line below** or
 - b. it is used to change values (decrement).

Entering the Service Mode



Press **OK** to enter the Service mode

Entry Code

After entering the Service Mode, a code is requested



Enter the 4 digit code and press **OK**

Use the arrow key to change values.



- The standard service code is: 1111.
- If you enter the wrong code, you will be redirected back to the **first digit**.
- If you change the Entry Code store it in a safe place. Without Entry Code you have no access to the service mode.
- **If you loose your Entry Code you MUST send the DFM-BC to the factory for resetting it to its default value (see Return of Instruments).**

Configuration (Sensor Type, Return Line Sensor, User Reset, AUX)

Move the bar over the line you would like to change parameters. Press OK. The changeable field will be highlighted for changing. Make your changes and press OK to accept the changes. If there are security questions, answer it with YES or NO.

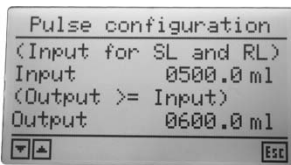

Input value: enter the value of the signal (ml/pulse) which is coming from the flow meter used (see table). This value is used also for the second flow meter (if any installed).

Sensor Type	Input Value
DFM-8S	12.5 ml
DFM-20S	36 ml
DFM-25S	100 ml

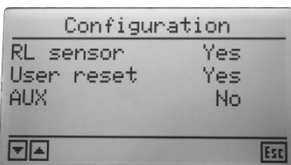

Output Value: enter the value of the outgoing pulse (value between 1-9'999 ml/pulse).

Remember: the "Output Value" should not be lower than the "Input Value".

RL sensor: Is a Return sensor installed? Answer this question according to the measurement method you do use (difference measurement or direct measurement) Attention: incorrect setting of this parameter will result in wrong consumption calculation.

User Reset: Is the user allowed to reset the TRIP? Choose between YES or NO.

AUX: If you answer with YES, the calculating consumption will be send to the auxiliary port (for Fleet Manager or GPS Tracking Systems)

and the screen of the DFM-BC will only show the word AUX



Supply Line (Total, TRIP, Current)

Move the bar over the line you would like to change parameters. Press OK. The changeable field will be highlighted for changing. This action will be followed by security questions. Answer the question with YES or NO until the value will be changed.

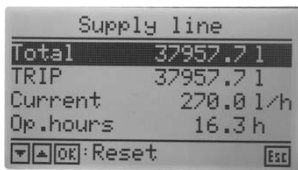

Supply line	
Total	37957.7 l
TRIP	37957.7 l
Current	270.0 l/h
Op. hours	16.3 h
[Left] [Right] [OK]: Reset [Esc]	

Total: Reset of the total amount of the fuel which is passed through the supply line since commissioning. This value must be reset in case the sensor is changed.

TRIP: Reset of the total amount of the fuel which is passed through the supply line since the last reset.

Current: No function will be activated.

Op. hours: Reset of the total amount of working hours of the supply line sensor since commissioning. This value must be reset in case the sensor is changed.

Return Line (Total, TRIP, Current)

Move the bar over the line you would like to change parameters. Press OK. The changeable field will be highlighted for changing. This action will be followed by security questions. Answer the question with YES or NO until the value will be changed.

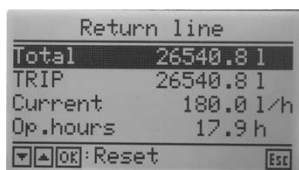

Return line	
Total	26540.8 l
TRIP	26540.8 l
Current	180.0 l/h
Op. hours	17.9 h
[Left] [Right] [OK]: Reset [Esc]	

Total: Reset the total amount of the fuel which is passed through the return line since commissioning. This value must be reset in case the sensor is changed.

TRIP: Reset the total amount of the fuel which is passed through the return line since the last reset.

Current: No function will be activated.

Op. hours: Reset of the total amount of working hours of the return line sensor since commissioning. This value must be reset in case the sensor is changed.

Consumption Overview (Total, TRIP, Consumption)

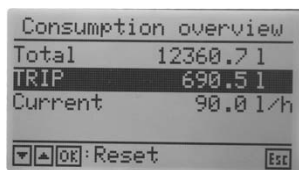

Consumption overview	
Total	12360.7 l
TRIP	690.5 l
Current	90.0 l/h
[Left] [Right] [OK]: Reset [Esc]	

The only thing you can change is the **TRIP**. Press OK to reset this value. This action will be followed by security questions. Answer the question with YES or NO until the value will be changed.

The rest is only to show you the calculated difference between the supply line and the return line

Supply Configuration (SL KF, SL app, Qmax)

Move the bar over the line you would like to change parameters. Press OK. The changeable field will be highlighted for changing. Make your changes and press OK to accept the changes. If there are security questions, answer it with YES or NO.

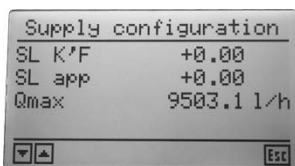

Supply configuration	
SL K'F	+0.00
SL app	+0.00
Qmax	9503.1 l/h
[Left] [Right] [OK]: Modify [Esc]	

SL K'F: Enter the SL K'F-value (or K'F-value) which you will found on the type plate of the sensor. This value is to optimize the sensor performance.

SL app: Put in a % value for a possible application correction. For more information go to the section "High Performance Results"

Qmax: This value shows you how high was the flow rate peak you ever had at the supply line. No changes are possible.

Return Configuration (SL KF, SL app, Qmax)

Move the bar over the line you would like to change parameters and press OK. The changeable field will be highlighted for changing. With the **▲ arrow** and the **▼ arrow** you can change the selected value

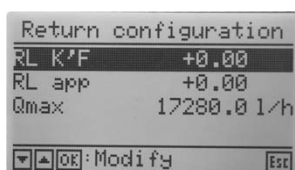

Return configuration	
RL K'F	+0.00
RL app	+0.00
Qmax	17280.0 l/h
[Left] [Right] [OK]: Modify [Esc]	

RL cal: Enter the RL K'F-value (or K'F-value) which you will found on the type plate of the sensor. This value is to optimize the sensor performance.

RL app: Put in a %value for a possible application correction. For more information go to the section "High Performance Results"

Qmax: This value shows you how high was the flow rate peak you ever had at the return line. No changes are possible

Error Log Entry



Press **OK** to enter the error log

Read the stored Error Messages (Error Log)

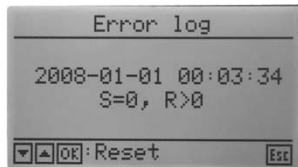

With the **▲** arrow and the **▼** arrow you can scroll through the messages
Each message has a data and time stamp. After the last message is reached the first message will be showed.

The messages consist in a short words-explanation about what error has happened
For more information about Error Messages see section Description of the Error Messages

Reset: To reset the Error Log press the OK key. This will lead you to the next **2 security questions**.

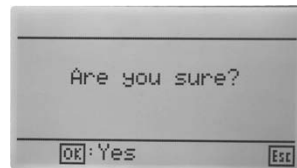
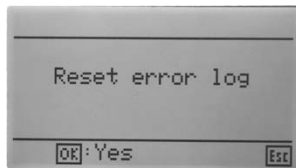

This two security questions avoid an accidentally deleting of the log
Be aware: after the reset action is done, the error log is empty. No recovery is possible

Config Log Entry

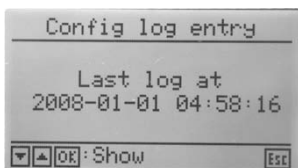

Press **OK** to enter the Config log

Read the stored Config Messages (Config Log Entry)



With the **▲** arrow and the **▼** arrow you can scroll through the messages
Each message has a data and time stamp. After the last message is reached the first message will be showed.

The messages consist in a short words-explanation about what changes has made

Reset: To reset the Config Log press the OK key. This will lead you to the next **2 security questions**.

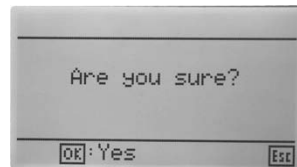
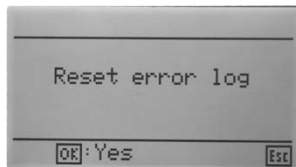

This two security questions avoid an accidentally deleting of the log
Be aware: after the reset action is done, the error log is empty. No recovery is possible

Clock

Move the bar over the line you would like to change parameters. Press OK. The changeable field will be highlighted for changing. Make your changes and press OK to accept the changes. If there are security questions, answer it with YES or NO.

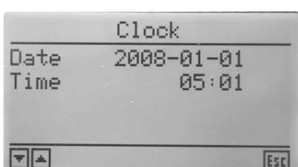

Move the bar over the line you would like to change parameters and press OK. The changeable field will be highlighted for changing.

With the **▲** arrow and the **▼** arrow you can change the selected value

With the <OK> key and the <ESC> key you can move from right to left to right.

Factory data

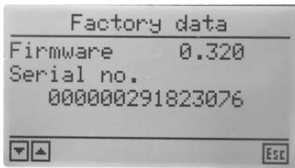

No changes are possible. The displayed information is needed for updates or internal use.

Error condition

Error Messages

If an error has occurred and it has consequence for the following digital readouts

Total or TRIP or the Consumption

than the Board Computer (DFM-BC) will show the following on the display:

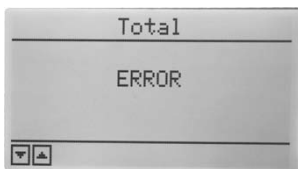

...and after 5 seconds...

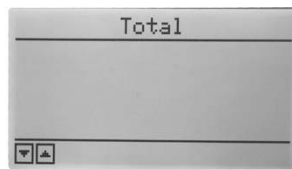

The DFM-BC will show an empty display until the correct results are available. There is no need for actions.

Description of the Error Messages



In any case, if an error occurs look at the **Error Log** to define what exactly happened and at what time. To check the installation is also a recommended approach for founding faults. The following messages will be displayed if an error occurs:

S>0 & R=0

Supply line Sensor has a flow rate. **Return line Sensor has no flow rate.**

Possible causes:

- Leak on the return line before it enter the sensor.
- Was the connection on the return line unscrewed? Why? Set it tight.
- Check for loose joint of the wires.
- Return Line Sensor defect.

S=0 & R>0

Supply line Sensor has no flow rate. **Return line Sensor has a flow rate.**

Possible causes:

- Leak on the supply line before it enter the sensor.
- Was the connection on the supply line unscrewed? Why? Set it tight.
- Check for loose joint of the wires
- Supply Line Sensor defect.

S>0 & R>0 & S<R

Supply line Sensor has a flow rate. Return line Sensor has a flow rate. **But the Supply line Sensor flow rate is smaller than Return Line Sensor flow rate.**

Possible causes:

- Leak on the supply line before it enter the sensor.
- Was the connection on the supply line unscrewed? Why? Set it tight.
- Check the temperature difference between the 2 lines. Remember: 10 °C of temperature difference mean an volume increase of 0.8 %.
- Check for loose joint of the wires.
- Supply Line Sensor defect.

S<0

Supply line Sensor has no flow rate.

Possible causes:

- Leak on the supply line before it enter the sensor.
- Was the connection on the supply line unscrewed? Why? Set it tight.
- Check for loose joint of the wires.
- Supply Line Sensor defect.

R<0

Return line Sensor has no flow rate.

Possible causes:

- Leak on the return line before it enter the sensor.
- Was the connection on the return line unscrewed? Why? Set it tight.
- Check for loose joint of the wires.
- Return Line Sensor defect.

If you have no success in finding out the reason of the fault, please call your local supplier.

Higher Performance Results (with application optimization)



High Performance Results means, to adapt the system to the different condition you can face during your daily work. This can be:

1. High ambient temperatures.
2. Low ambient temperatures.
3. Different temperatures between supply line and return line of the fuel system.
4. Something else...

To avoid the influence of all the mentioned conditions listed above, the Board Computer get you the unique possibility to optimize your application. **It is an application optimization** because the CONTOIL® DFM System it-self works perfect but the condition around it changes. To take care of this situation you can adjust the calculation according to your experience on the field.

Let's look at an example:

The temperature of the return line fuel is 10 °C higher than the temperature of the supply line fuel. This temperature difference cause a **volume increase of about 0.8 %** on the return line.

Note: all 10 °C the volume of the fuel will increase for approximately 0.8 %. This statement is based on a large experience of the developer of the CONTOIL® DFM.

To compensate this fact, enter on the RL app parameter the value -0.8 %. From now on the calculated flow on the return line will be -0.8 % reduced. This reduced flow will be used for the consumption calculation. The same you can do with the SL app.

How to enter this parameter?

Go to the section "For Service Peoples ... parameter settings" enter the sub-section "Return Configuration" and change the "PL app" value.

What is to do if it is not functioning?

No Display on the Board Computer (DFM-BC)

1. The Board Computer (DFM-BC) has a sleep mode. Press any key the wake it up. It is ok? If not go to the check list below.
2. Check the following:
 - a. Has the vehicle battery min. 12 VDC?
 - b. Power connections from the vehicle battery to the Board Computer (DFM-BC). Do you have min.12 VDC? If not the check the connection for wire interrupts.
 - c. Are the wires from the vehicle battery connected to the Board Computer (DFM-BC) (pin 13 (battery plus) and pin 14 (battery minus) of the connector inside the case)?
 - d. If the display is still not working, disconnect all wires except the ones from pin 13 (battery plus) and pin 14 (battery minus).
 - i. It works!
The problem may be by an incorrect connection of the wires from the sensor or from the auxiliary device.
 - ii. It still did not work!
Contact your local dealer for more information.

The Board Computer (DFM-BC) is running, but no value from the Sensors

1. Check the following:
 - a. Are the Sensors connected to the Board Computer?
 - b. Check the voltage on the Board Computer for the Sensors (pin 1 and/or 7). It must be at least 12 VDC.
See also section "Electrical connections and specifications".

After Installation, an <Error> is displayed.

1. Check the following:
 - a. Are the DFM Sensor mounted the right way (look for the direction arrows on the sensors).
 - b. Look at the Error Log and try to found out the solution with the **description of the Error Messages**

Electrical Connections and Specifications

For the DFM-8D



Explanation of the wires:



Black	Input voltage 12-24 VDC from the DFM-BC or from another source. If you use another source, make sure the voltage is stable and filtered
Brown	Ground (take the same ground like the 12-24 VDC source).
Yellow	“Supply Line Right” (SL-R). On this line a signal is send only if the rotary piston is rotated the correct way.
Green	“Supply Line False” (SL-F). On this line a signal is send only if the rotary piston is rotated the false way.
Reed	“Return Line Right” (RL-R). On this line a signal is send only if the rotary piston is rotated the correct way.
White	“Return Line False” (RL-F). On this line a signal is send only if the rotary piston is rotated the false way.

For the DFM 8S / 20S / 25S



Explanation of the wires:



Black	Input voltage 12-24 VDC from the DFM-BC or from another source. If you use another source, make sure the voltage is stable and filtered
Brown	Ground (take the same ground like the 12-24 VDC source).
Yellow	“Supply Line Right” (SL-R). On this line a signal is send only if the rotary piston is rotated the correct way.
Green	“Supply Line False” (SL-F). On this line a signal is send only if the rotary piston is rotated the false way.
Reed	Not used for this Sensor-Meter.
White	Not used for this Sensor-Meter.

Attention:

the signal is a pull down transistor, that means, whenever a signal should be generated, this line will go to ground (Open Drain).

For the DFM-BC

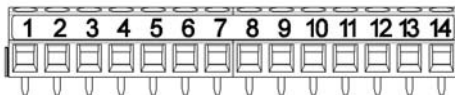

Explanation of the wires:

- Pin 1:** Power supply for the Sensor-Meter. This connection is used to feed the following Sensor-Meter: DFM-8D, DFM-8S, DFM-20S, DFM-25S or other.
- Pin 2:** Ground for the Sensor-Meter. This connection is used as ground for the following Sensor-Meter: DFM-8D, DFM-8S, DFM-20S, DFM-25S and other.
- Pin 3:** Input for Supply Line Right (SL-R), means rotating the correct way. This connection is used for the DFM-8D, DFM-8S, DFM-20S, DFM-25S and other.
- Pin 4:** Input for Supply Line False (SL-F), means rotating the wrong way. This connection is used for the DFM-8D, DFM-8S, DFM-20S, DFM-25S
- Pin 5:** Input for Return Line Right (RL-R), means rotating the correct way. This connection is used exclusively. for the DFM-8D.
- Pin 6:** Input for Return Line False (RL-F), means rotating the wrong way. This connection is used exclusively for the DFM-8D.
- Pin 7:** Power supply for the second Sensor-Meter. This connection is used to feed the following Sensor-Meter: DFM-8S, DFM-20S, DFM-25S and other. Use this connection for the Return-Line Sensor Meter.
- Pin 8:** Ground for the second Sensor-Meter. This connection is used as ground for the following Sensor-Meter: DFM-8S, DFM-20S, DFM-25S and other. Use this connection for the Return-Line Sensor Meter.
- Pin 9:** Input for Return Line Right (RL-R). This connection is used for the following Sensor-Meter: DFM-8S, DFM-20S, DFM-25S and other. Use this connection for the Return-Line Sensor Meter.
- Pin 10:** Input for Return Line False (RL-F). This connection is used for the following Sensor-Meter: DFM-8S, DFM-20S, DFM-25S. Use this connection for the Return-Line Sensor Meter.

- Pin 11:** Signal for the external device
Connect here the Analog/Digital cable from the Fleet-Manager or GPS-Tracking-System.
Attention: the signal is a pull down transistor, that means, whenever a signal should be generated, this line will go to ground (Open Drain).
- Pin 12:** Ground for the external device.
Connect here the ground cable from the Fleet-Manager or GPS-Tracking-System.
- Pin 13:** Plus Power Supply connection from the vehicle battery (12-24 VDC)
- Pin 14:** Minus Power Supply connection from the vehicle battery

Flow-Sensor	l/pulse (ml/pulse)	Hz (max.)	Pulse interval (min.)	Pulse width	mA (max)	VDC (Nominal)
Double Sensor DFM 8D	0.0125 (12.5)	15	46 ms	20 ms	10	12-24
Single Sensor DFM 8S	0.0125 (12.5)	15	46 ms	20 ms	10	12-24
Single Sensor DFM 20S	0.036 (36)	15	46 ms	20 ms	10	12-24
Single Sensor DFM 25S	0.100 (100)	15	46 ms	20 ms	10	12-24

Explanation of the power on the DFM-BC pins:

Pin number	VDC	mA max.
1 (+)	12-24	10
2 (-)	GND	
7 (+)	12-24	10
8 (-)	GND	

Connection of non Aquametro flow meters

	Pin number		
Flow meter 1	2	GND	Connection for the "supply line" flow meter or for the flow meter for direct consumption measurement
	3	+	
Flow meter 2	8	GND	Connection for the "return line" flow meter only if you have a differential consumption measurement
	9	+	

Electrical scheme of the DFM signal

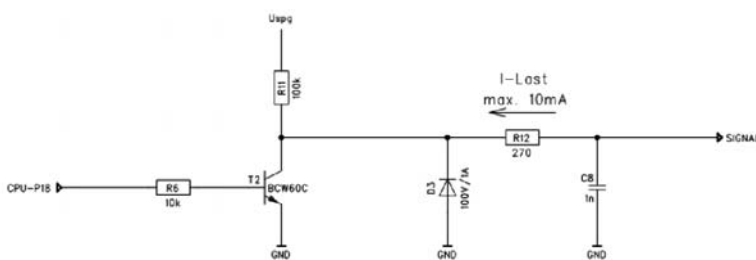

If you do not use the Board Computer (DFM-BC), please look at the Fuel Counter Manual you purchased for a correct connection of the DFM-Sensor wires.

Electrical scheme of the DFM Systems

DFM-BC to DFM 8D

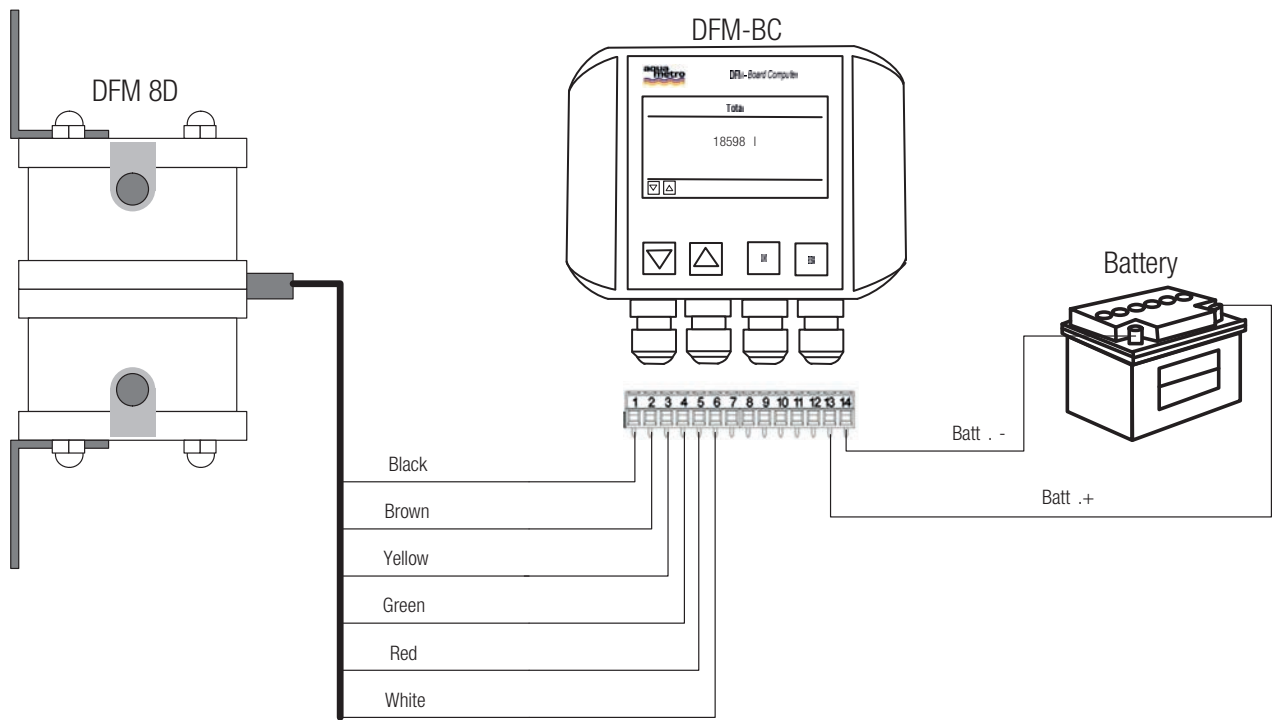

DFM-BC to DFM 8S / 20S / 25S for differential consumption

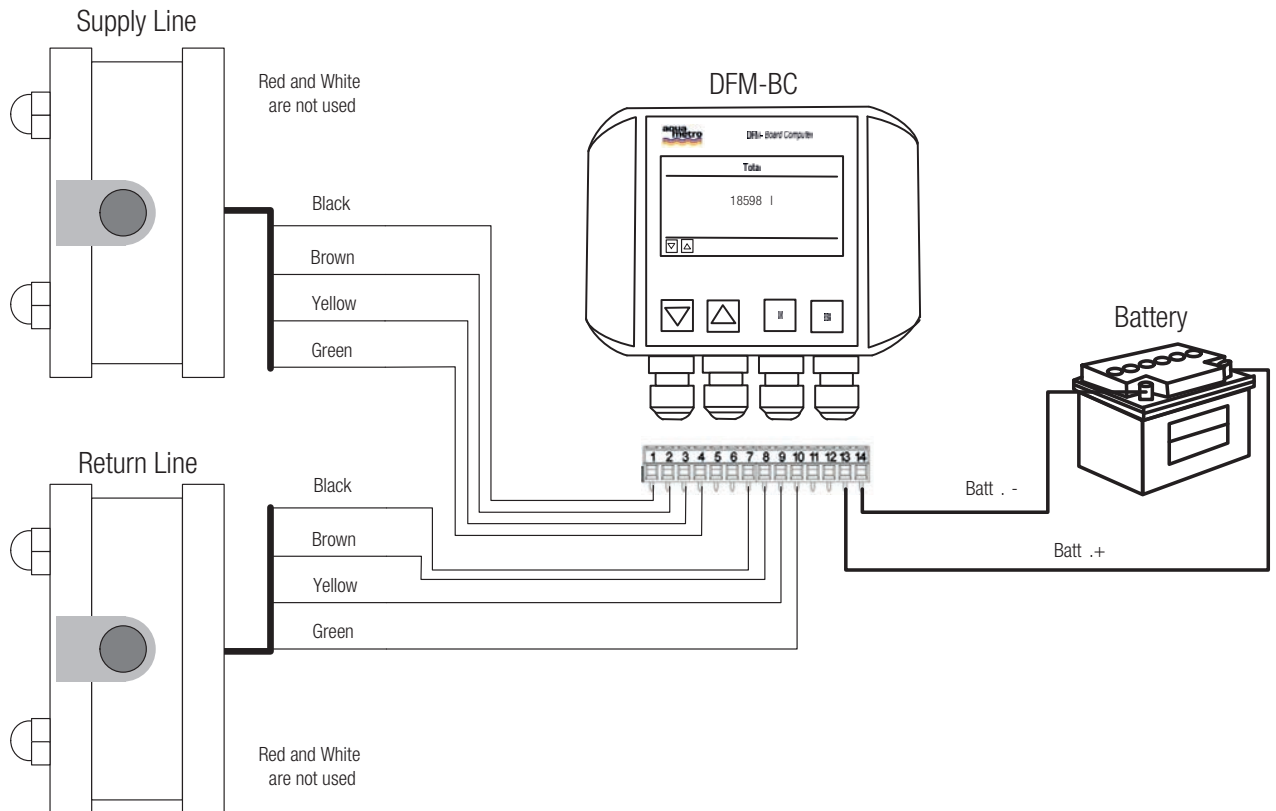

DFM-BC to DFM 8S / 20S / 25S for direct consumption

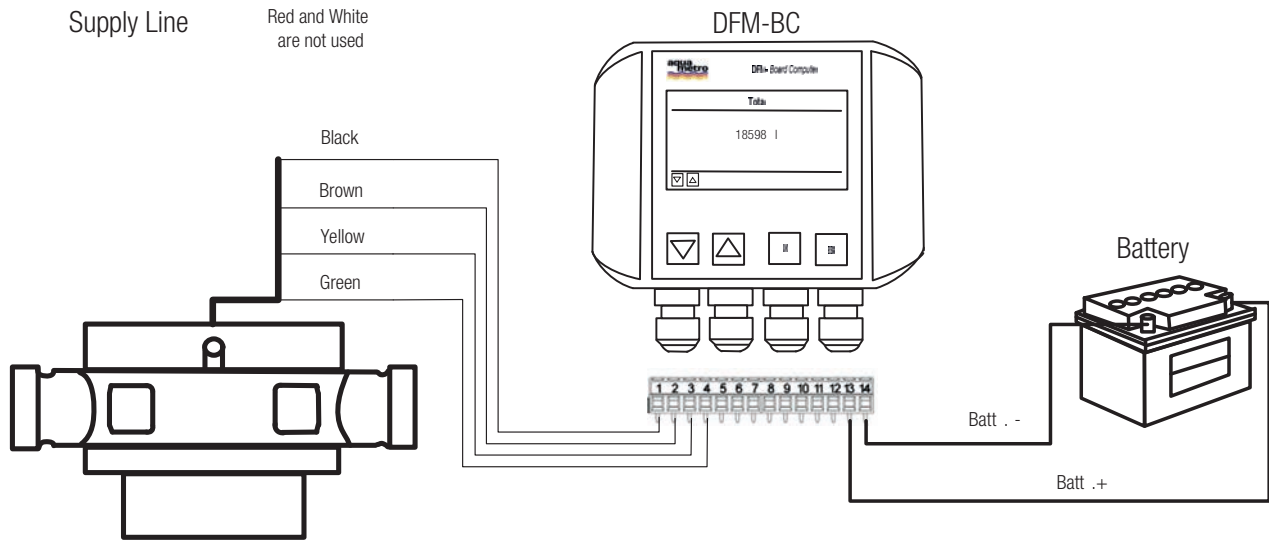

DFM-BC to Fleet Manager or GPS-Tracking System

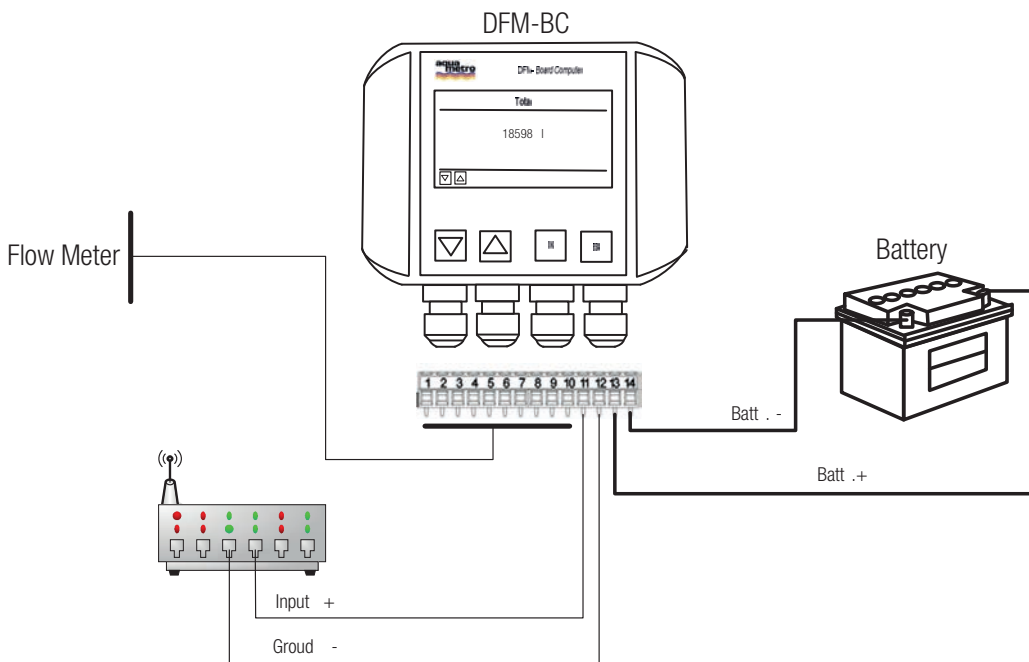

Specification and Technical Data

Flow sensors		DN 8	DN 20	DN 25
Max supply flow rate Qn ¹⁾	l/h	180 (135)	1000 (1000)	2000 (2000)
Max. engine consumption approx.	l/h	100	600	1200
Min. flow rate at measuring point approx. ¹⁾	l/h	20 (4)	100 (30)	200 (75)
Max. operating pressure	bar	16	16	16
Approx. pressure drop at Qn	mbar	150	150	150
Max. measuring error per sensor	%	±1	±0.5	±0.5
repeatability	%	±0.2	±0.1	±0.1
Operating temperature	° C	-20...+80	-20...+80	-20...+80
Ambient temperature ²⁾	° C	-40...+125	-40...+125	-40...+125
Max. filter mesh size	mm	0.100	0.100	0.250
Protection class according to IEC 60529		IP 66	IP 66	IP 66
Hydraulic connections		M14x1.5mm	G 1"	G 1 ¼"
Recommended connectors:	size	M14x1.5mm	G 3/4"	G 1"
	part number	80447	81166	81169
Cable 6 x 0.5 mm ² , outer dia. 6.2 mm, length 7.5 m		included	included	included
Safety: Vehicle approved for vibration, shock and electrical immision and emission.		yes	yes	yes

¹⁾ Differential measurement (direct consumption measurement)

²⁾ Within this temperature (-40...-21 °C / +81...+125 °C) the sensor will not be damaged, but the proper operation is not assured.

Board Computer

Power supply	12...24 VDC direct from vehicle battery
Registration	100.000.000 litres
Scale value	Default for DN 8 = 80 pulses per liter
Temperature	Ambient -10 ... +70 °C,
Protection class	IP 54 according to IEC 60529
Electrical connection	Power supply with cable 2 x 0.75 mm ² , 2 m supplied Cable outer diameter 5.0 mm

Dimensions

DFM-8S / DFM-8D

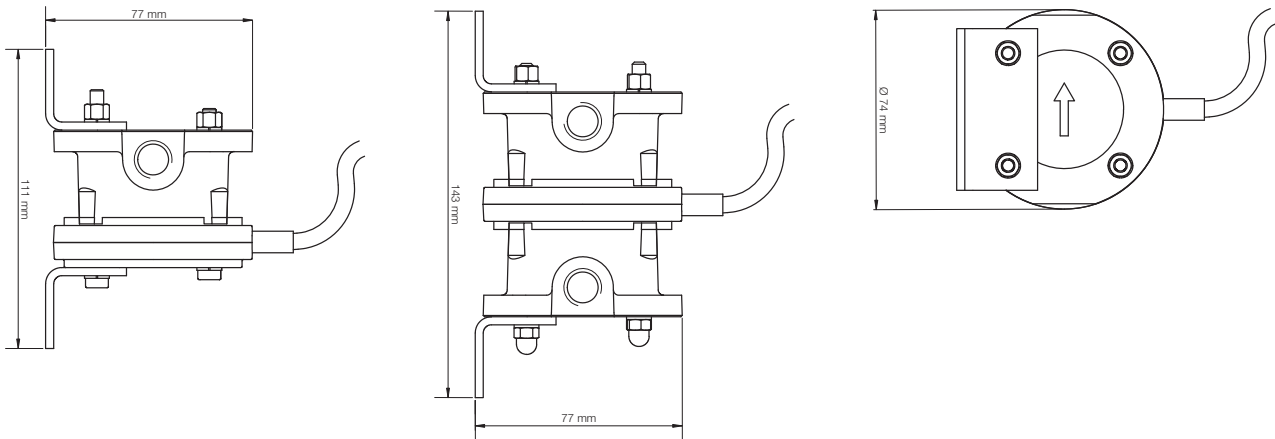

Flow-Sensors DFM 20S and DFM 25S

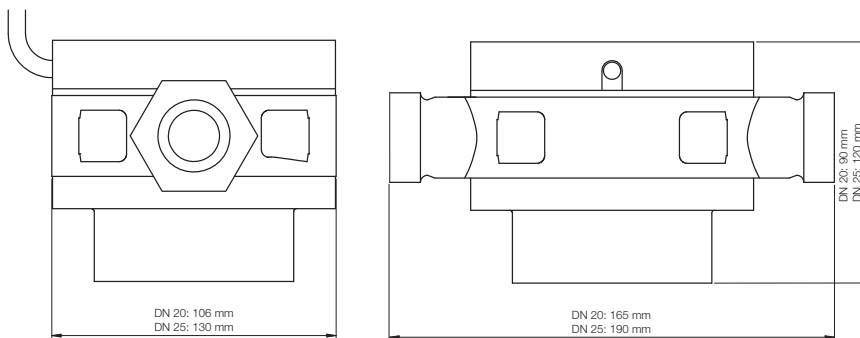

Zählernennweite	L	B	a	Ø F	b	h1	p	r
DN20	165	105	260	105	54	74	G 1"	G 3/4"
DN25	190	130	305	115	77	101	G 1 1/4"	G 1"

DFM-BC

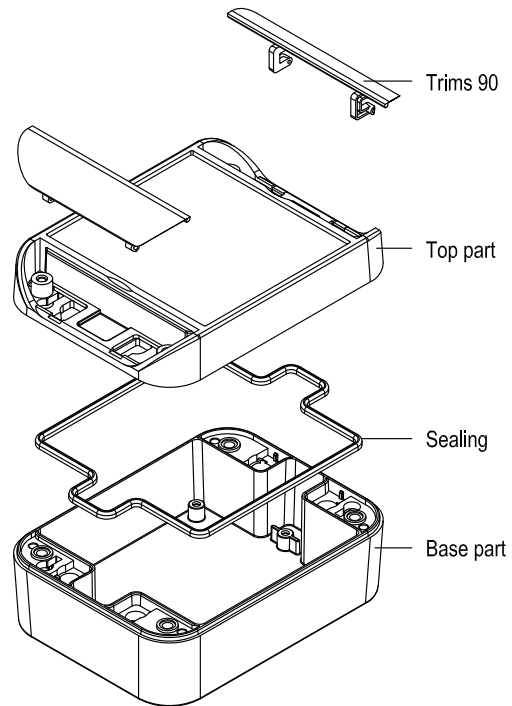
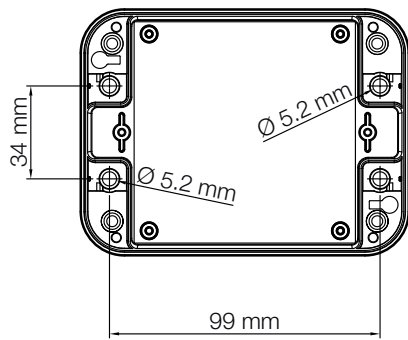
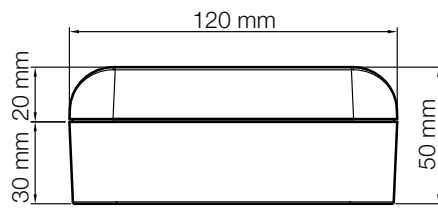
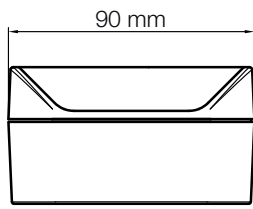

Ordering Information

Description	Type	Part. no.
Diesel fuel flow sensor DN 8D (double)	DFM8D	94465
Diesel fuel flow sensor DN 8S (single)	DFM8S	94464
Diesel fuel flow sensor DN 20S (single)	DFM20S	94466
Diesel fuel flow sensor DN 25S (single)	DFM25S	94467
Board Computer	DFMBC	94476
Hose Connector for DN 8 (M14 x 1.5mm)	DFM8S/D	80447
Pipe Connector for DN 20	VSR 3/4"	81166
Pipe Connector for DN 25	VSR 1"	81169

Warranty Information

All Aquametro products are produced under high quality levels and ISO 9001 standards. Every single flow sensor is submitted to an accuracy test that is documented in a test protocol. The test benches used for this process are under constant control of the Swiss and the German authorities (METAS and PTB). The electronic products have to pass an individual quality test. Therefore Aquametro guarantees for the Product Quality (perfect material, machining and function) of every delivered product. Further details are specified in our terms of business.

As Aquametro does not have a direct influence to the Installation and Application Quality we cannot take any responsibility for this part.

SALES PARTNER: H. Hermann Ehlers GmbH

An der Autobahn 45
28876 Oyten
Tel. 04207/91 21-0
Fax 04207/91 21 -41

Email : verkauf@ehlersgmbh.de